

Adaptive Digital Technologies

Network Packet-based Intercom / IP Phone Software Subsystem (ISS) OMAP35x

Compatible TI DSP: OMAP35x

Adaptive Digital's ISS software subsystem simplifies software design of an IP intercom or IP phone that runs on the TI's OMAP3530 processor. ISS implements complete VoIP capability all the way from PCM to Packet and back. This includes a process running on the ARM under Linux as well as the necessary voice-processing running on the DSP core.

A user's application, co-resident on the ARM, can set up and tear down VoIP channels via the ISS API. The ISS software takes care of everything else.

The intercom system utilizes a TCP/IP client-server model for status and control.

The API functions running on the client-side of the interface format messages that are sent over a connected socket to the server. The server side of the interface responds to these messages by calling the appropriate G.PAK API functions, which in turn, control the DSP. Subsequent status messages are returned to the client.

The server software runs as a Linux process on the OMAP3530. In addition to supporting client messages, the server process is responsible for booting and downloading the DSP portion of the OMAP device, controlling the DSP's operation, and the timely transfer of RTP packets between the network stack and the DSP software.

About G.PAK:

G.PAK is a scalable and configurable voice-over-packet DSP software solution that turns a DSP into an easily controlled voice-over-packet engine. G.PAK integrates the building blocks that are required in voice-over-packet systems into a turnkey solution.

FEATURES & BENEFITS

- ◆ The VoIP Intercom ISS features three modes of RTP connectivity; point-point (full-duplex), point-to-multi-point (half-duplex), and broadcast (half-duplex).
- ◆ The VoIP software includes Adaptive Digital's Gen-4 Acoustic Echo cancellation, which incorporates a noise reduction feature, as well as anti-howling, nonlinear processing, and double-talk detection.

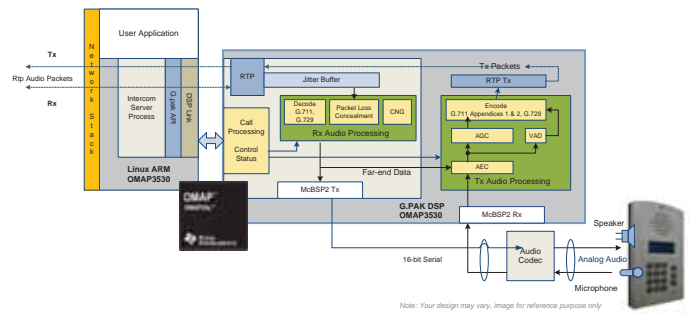

- ◆ VOICE PROCESSING FUNCTIONS INCLUDE: Digital Gain Control, Noise Reduction, Vad/CNG, RTP & Jitter Buffer, AGC, G.711 m-Law, G.711 A-Law, and G.729AB.
- ◆ The combination of TI's OMAP35x processor and Adaptive Digital's superior algorithms and G.PAK framework, provide a solid foundation for the development of differentiated next-gen telecom products.
- ◆ Adaptive Digital's VoIP Intercom ISS enables equipment manufacturers to develop products quickly and cost-effectively.
- ◆ Should modifications be necessary for your project, customization is available.

AVAILABILITY

Available Now

APPLICATION AREAS

Broadband, Communications & Telecom, Consumer Electronics, Industrial, Medical, Military, Security, Wireless



CONTACT INFORMATION



**ADAPTIVE
DIGITAL**
TECHNOLOGIES



Kane Computing Ltd
7 Theatre Court, London Road,
Northwich, Cheshire, CW9 5HB, UK.
Tel: +44(0)1606 351006
Fax: +44(0)1606 351007/8
Email: sales@kanecomputing.com
Web: www.kanecomputing.co.uk

Application-Specific Libraries