

HD Video Surveillance IP Camera Reference Designs



Multiple IP Camera Solutions Enable Quick Product Development at Low Analog Camera Price Points

Texas Instruments offers multiple highly optimized reference designs based on the TMS320DM3x digital media processors with DaVinci™ technology for the IP camera market to enable developers to speed through the design process as well as reducing overall bill of materials costs. These reference designs:

- Reduce development time by 98 percent
- Deliver higher quality, wider field-of-view HD images
- Decrease electronic bill of materials
- Empower customers to bring U.S. \$150 HD IP cameras to the market

These solutions reduce development to under four months by including:

- Complete and optimized schematics
- Gerber files

- Free Linux application source code, including:
 - Integrated auto white balance and auto exposure
 - Simple motion detection
 - Dual-stream HD MPEG-4 and MJPEG video codecs to support

recording and monitoring needs at full frame rates

- DaVinci IP camera software framework including I/O application programming interfaces (APIs), media APIs and DaVinci Codec Engine

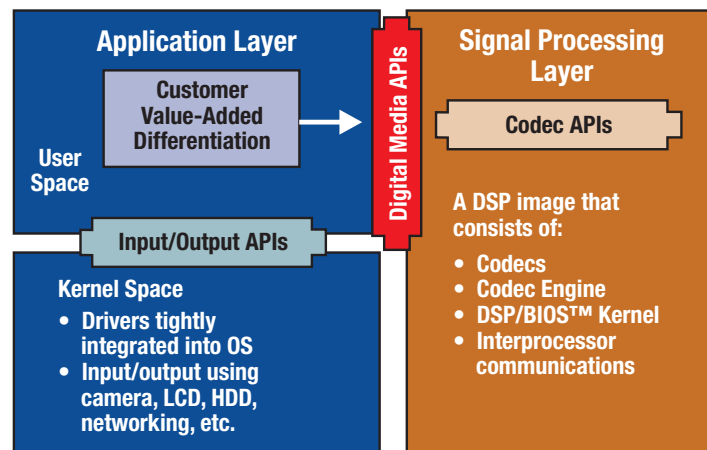

▲ TMS320DM3x-based IP camera reference design software

Multiple Reference Designs Available Based on TI Technology:

TI's DM3x-based IP camera solutions are:

- **New DM365 IP Camera Reference Design** (part #: DM365IPNC-MT5): Single-platform solution provides H.264 in HD
- **Wide Dynamic Range (WDR) IP Camera Reference Design**

- (part #: DM355IPNC-TC922): includes base version plus WDR technology from Texas Instruments
- **Video Content Analytics (VCA) IP Camera Reference Design** (part #: DM355IPNC-VCA1):

includes base version plus VCA technology from Object Video

- **DM355 IP Camera Reference Design** (part #: DM355IPNC-MT5): supports high definition (HD) at 1.3 MPixel CMOS sensor technologies from Aptina

Order via www.ti.com/ipcamera

DM365 IP Camera Reference Design: DM365IPNC-MT5

TI and Aptina Imaging (a division of Micron) have come together again to bring to market a single platform, H.264 reference design for faster development at a reduced cost.

Hardware features

- TI TMS320DM365 digital media processor based on DaVinci™ technology includes ARM926 and H.264 HW video coprocessor, EMAC, RTC and integrated voice codec for BOM savings
- Aptina 5-MP sensor CMOS imager optimized for low-light performance
- Board size 65×50 mm, low-power (3W)

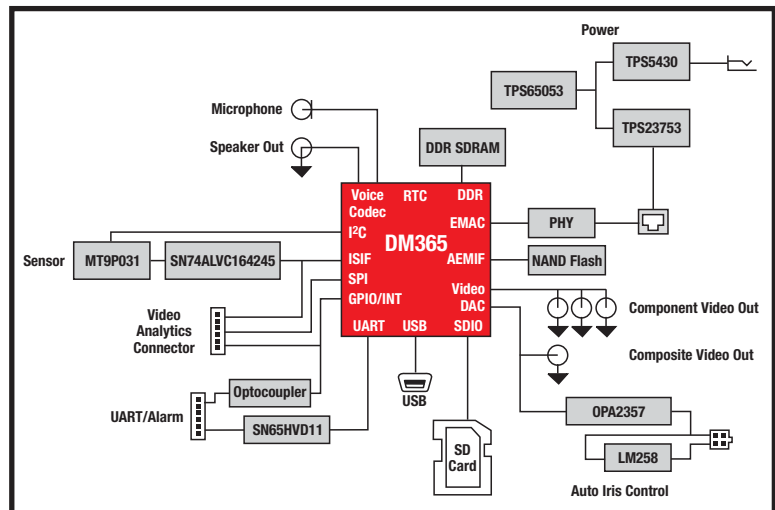

▲ DM365 IP Camera Reference Design block diagram: DM365IPNC-MT5



▲ DM365IPNC-MT5 IP Camera Reference Design available from Apro Photoelectron Inc.

- Power over Ethernet, audio, SD storage

Software features

- Complete Linux-based IP net camera application including free source code
- Encode up to H.264/MPEG-4 HD 1080p at reduced frame rate or 720p full frame rate
- Triple stream per channel (H.264, MPEG-4, MJPEG)

- Integrated auto white balance and auto exposure
- Royalty-free, production-ready codecs included
- Software framework includes input/output and media APIs, codec engine
- Ability to add video analytics with DaVinci TMS320DM643x DSP
- PSIA standard support

Wide Dynamic Range (WDR) IP Camera Reference Design: DM355IPNC-TC922

TI has brought to market the WDR version of the original TMS320DM355-based IP camera reference design which exceeds CCD image quality with high-clarity SVGA 60p.

Hardware features

- TMS320DM355 SoC, ARM926 and hardware video coprocessor
- TC922 TI's WDR CMOS imager optimized for high-light/low-light performance

- Board size 65×50 mm
- Low power (< 3 W)

Software features

- Complete Linux-based IP network camera application including free source code
- Dual-stream capabilities
 - MPEG-4 SVGA+ MJPEG VGA + G.711



▲ DM355IPNC-TC922 IP Camera Reference Design available from Apro Photoelectron Inc.

- Triple-stream capabilities
 - MPEG-4 SVGA + MJPEG VGA + MPEG-4 QVGA + G.711
 - MPEG-4 VGA + MJPEG VGA + MPEG-4 QVGA + G.711
- Integrated auto white balance and auto exposure
- Field-proven, robust, royalty-free bundled MPEG-4 and MJPEG video codecs
- DaVinci IP camera software framework including I/O APIs, media APIs and DaVinci Codec Engine
- Ability to add video analytics with DaVinci TMS320DM643x digital media processors

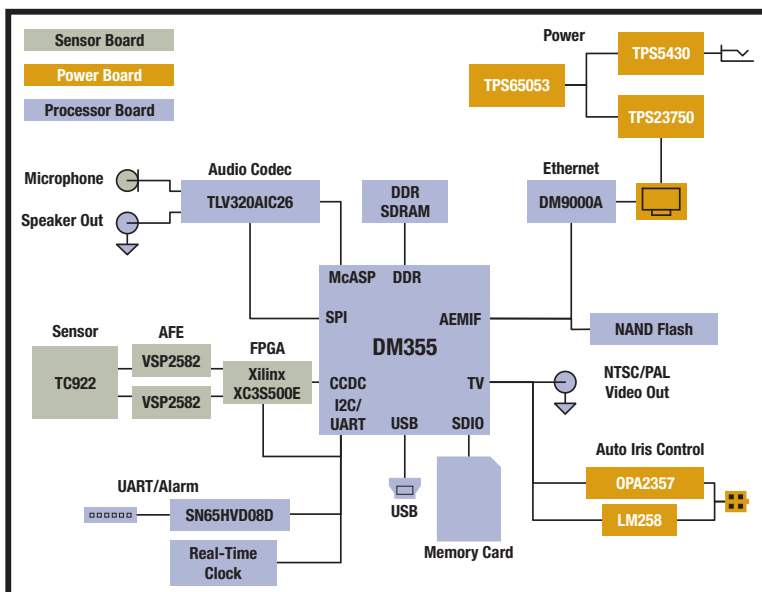

▲ WDR DM355 IP Camera Reference Design block diagram: DM355IPNC-TC922

Video Content Analysis (VCA) DM355 IP Camera Reference Design: DM355IPNC-VCA1

TI and Object Video have brought to market the VCA version of the DM355-based IP camera which supports Object Video intelligent video analytics. The analytics software provides simple monitoring and notification of security events through a web browser. This reference design builds on the base solution (DM355IPNC-MT5) with a VCA daughter board.

Hardware features

- DaVinci™ TMS320DM6435 digital media processor
- DaVinci TMS320DM355 SoC, ARM926 and hardware video coprocessor
- Aptina 5 MP sensor (2x2 binning ~1.3 MP)



▲ DM355IPNC-VCA1 IP Camera Reference Design available from Zero One Technology

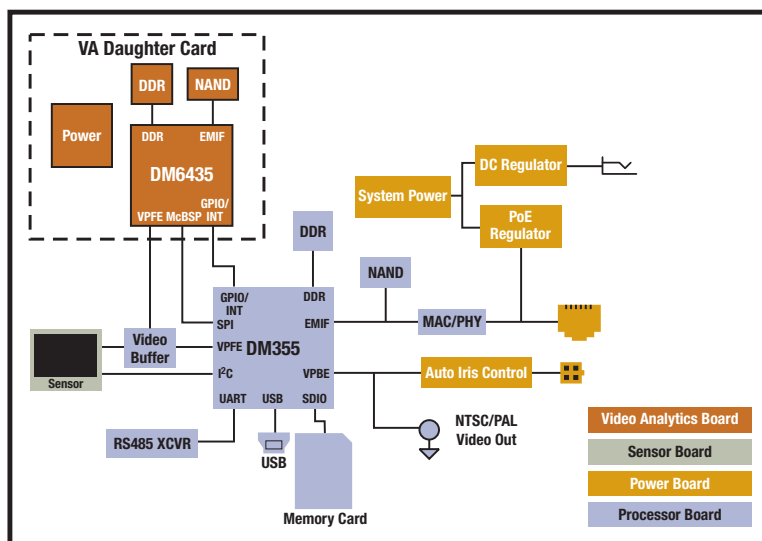

▲ VCA DM355 IP Camera Reference Design block diagram: DM355IPNC-VCA1

- VCA daughter board size 41x40 mm
 - Integrated auto white balance and auto exposure
 - Field-proven, robust, royalty-free bundled MPEG-4 and MJPEG video codecs
 - DaVinci IP camera software framework including I/O APIs, media APIs and DaVinci Codec Engine
- ### Software features
- Complete Linux-based IP network camera application including free source code
 - Dual-stream capabilities
 - MPEG-4 HD 720P + MPEG-4 CIF + G.711
 - Triple-stream capabilities
 - MPEG-4 HD 720P + MJPEG VGA + MJPEG CIF + G.711

