



AD40 - 40MHz Analog Input Module

The AD40 module features two, independent, very-high-speed analog input channels making it ideal for high-speed data acquisition and transient capture systems. Each channel employs Analog Devices' AD9224 monolithic, single supply 12-bit, 40 MSPS analog to digital converter with an on-chip, high performance sample-and-hold amplifier and voltage reference. The A/D uses a multistage differential pipelined architecture with output error correction logic to provide 12-bit accuracy at up to 40 MHz data rates, and guarantees no missing codes over the full operating temperature range. A single clock input is used to control all internal conversion cycles. An out-of-range signal indicates an overflow condition which can be used with the most significant bit to determine low or high overflow. Onboard circuitry adds gain/offset error adjustments for each channel to insure accurate measurements.

Each A/D channel features a 64K sample FIFO to allow efficient data collection and transport to the OMNIBUS host card. This allows the data collection from the A/D as single points (to minimize latency), or as a data set of up to a full FIFO depth (to minimize the interrupt rate to the host DSP).

Additional onboard logic supports powerful pre-triggering in which the FIFO is continuously refilled with fresh conversions until an external gating event is detected, after which a programmable number of samples are acquired (post-triggered).

Another powerful feature of the AD40 is the external level gating capability. Acquisition for each channel may be inhibited until the input level exceeds a programmable voltage threshold, after which acquisition is enabled or edge-triggered.

Software examples demonstrating module operation and communication are included in the Zuma/Armada Toolsets. A full calibration report ships with every module.

Interface	Compatible with all OMNIBUS host products Consumes one interrupt to host
Power Requirements	5V@600mA, +5V@100mA analog, -5V@70mA analog
Physicals	OMNIBUS mezzanine card; 2.000" X 4.600"
A/D Converters	2 Analog Devices AD9224 converters
Resolution	12-bit
Update Rate	40 MHz max.
Pipeline Latency	4 conversion clocks
External Clock Input	TTL (50 Ohm termination optional)
External Clock	0-40 MHz
Analog Input Range	± 1 V
SINAD	60 dB
S/N Ratio	63 dB
THD	-62 dB
Dynamic Range	75 dB
Gain Error	± 1.6 % FSR
SFDR	70 dB
INL	± 5 LSB
DNL	± 1 LSB
Offset Error	Trimmable on each channel - factory calibrated
Aperture Jitter	4ps RMS
Aperture Delay	1 ns
Input Type	Single Ended via MCX connector/channel
Input Impedance	50 Ohms
Conversion Trigger	Onboard clock osc. (40 MHz) or external clock via MCX into 50 Ohm load
Sources	
Sample FIFOs	64 K sample standard, memory mapped to DSP A/Ds are paired on bus as 32-bit numbers - each 16-bit half is an A/D. 64 K to support "snapshot" type applications
Pre-Trigger	Special logic supports pre-trigger up to entire FIFO depth

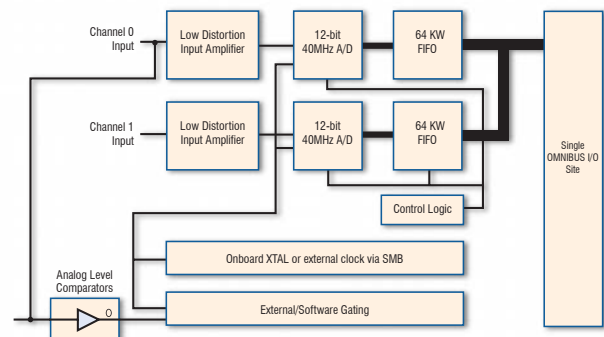

In System Performance

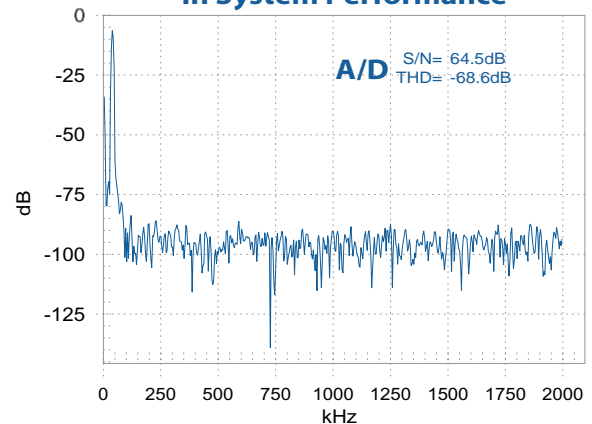

Ordering Information

AD40 - 64K FIFO	80020-17
BNC to MCX Cable	67020