

- Interface** Compatible with all OMNIBUS host products
Consumes one interrupt to host
- Power Requirements** 5 V @ 150 mA (no load on outputs)
+15 V @ 25mA; -15 V @ 25mA
- Physicals** OMNIBUS mezzanine card 2.000" X 4.600"
- Digital I/O** 32-bit total
- Direction Control** Configurable byte-by-byte for input or output
- Drive Capability** Drive capability 32 mA source/ 64 mA sink
Can directly drive opto-couplers and LEDs
- Data Triggering** Inputs latch on host read or external TTL clock
Outputs latched on DSP write
- Access Speed** Host OMNIBUS max.
- Interface to DSP** Memory-mapped
- Serial I/O** Two independent channels; Philips 26C562
- Serial protocols** Asynchronous : 5-8 bits, optional parity; Up to 38.4K baud
- Synchronous** Sync, bisync, SDLC etc; Up to 10 Mbit/sec
- Data FIFO** 16 character FIFOs on each channel
- Line Interfaces** RS232 or RS422, Factory configured
- Handshaking** RTS/CTS hardware handshaking
Jumper configurable
- Interface to DSP** Memory-mapped



DIG - Digital I/O and RS232/422 Module

The DIG OMNIBUS module provides 32-bit digital I/O and two serial ports. This module is commonly used for sensing digital inputs and as control bits for industrial process equipment. Additionally, the serial ports allow an easy interface to a wide variety of measurement and process control devices.

The DIG module's digital I/O port may be clocked at rates up to 8MHz and drive opto-couplers and industrial interface modules that allow control of high-current, high-voltage loads as part of a control or measurement system.

The DIG module has two serial ports that can be configured in numerous modes for both asynchronous and synchronous communications. Each serial port may be used at up to 10 Mbits per second in synchronous mode, or up to 38.4 kbaud in asynchronous mode. The serial ports allow the host card to communicate and control other instruments, act as a slave to a host processor, or work together in a multi-drop configuration for distributed processing. Serial line interfacing is factory configured as RS232 or RS422.

Software examples demonstrating module operation and communication are included in the Zuma/Armada Toolsets. UART functions are not supported in the Armada Toolset. A full calibration report ships with every module.

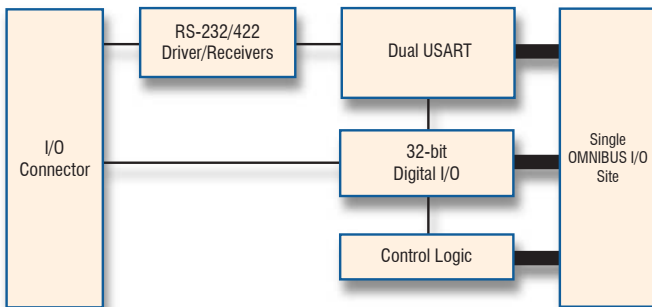

Input Latch Timing

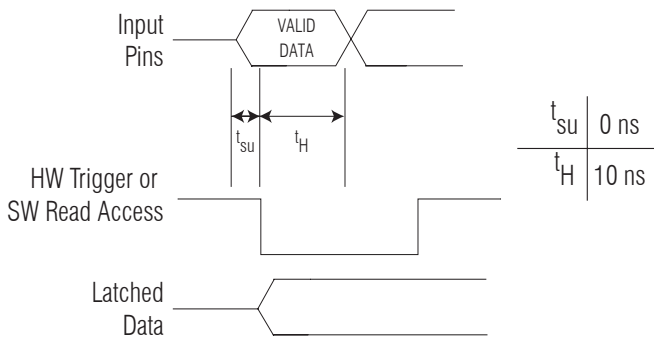

Ordering Information

DIG (with RS232)	80020-2
DIG (with RS422)	80020-11