

# 4-Wave advanced development solutions

## Reference sheet

Developing next-generation ground and wireless telecommunication systems—where voice, video, and data converge—takes up an ever increasing part of the efforts of today's developers.

Lyrtech offers the most versatile and integrated DSP-FPGA-based, triple/quadruple play advanced development solutions (ADSs) on the market to help in rapidly developing such applications. How? Because it can be scaled according to DSP and FPGA processing needs, because of its complete baseband-to-RF integration, and because it supports the Simulink model-based design flow from The MathWorks.



### Fully integrated solutions

Lyrtech's 4-Wave ADSs integrate a complete array of tools and features, making them easy to use and efficient.

- Language-based design flow
- Real-time data exchange tools with the host device CPU
- Recording and playback tools
- Direct and remote access capabilities
- Real-time and hardware-in-the-loop co-simulation capabilities
- DSP-FPGA video framework through a four-port SDRAM FPGA core
- And much more

### Voice, video, data, and wireless

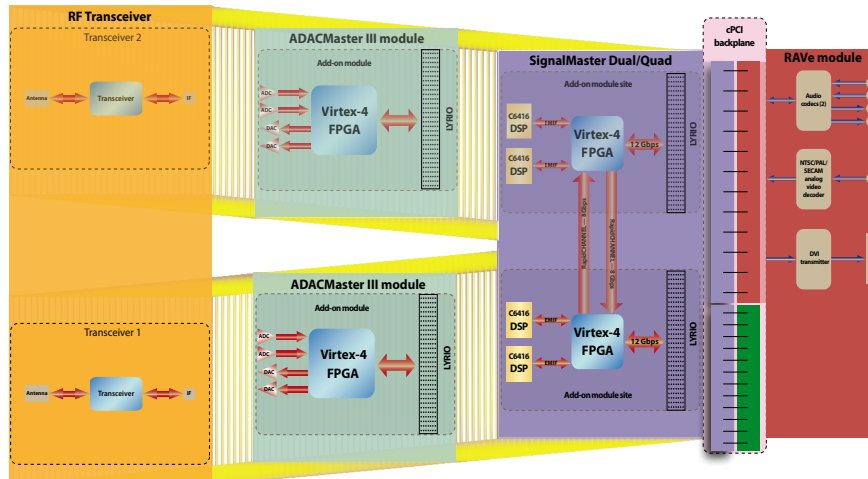

**Transceiver section (optional)**

- Two full-duplex transceivers
- Twin Tunable RF Transceiver
- Low-band range: 200-930 MHz
- High-band range: 1.6-2.3 GHz
- Software-selectable, 5 MHz or 20 MHz RX bandwidths
- Twin WIMAX RF Transceiver
  - 2.5-GHz WIMAX range: 2.3-2.7 GHz
  - 3.5-GHz WIMAX range: 3.3-3.8 GHz
  - Software-selectable, 7 MHz or 22 MHz RX bandwidths

**Wireless section (optional)**

- Two 14-bit, 125-MSPS ADC channels
- Two 16-bit, 500-MSPS interpolated DAC channels
- Multiple clock sources
- DC-coupled and AC-coupled options
- LX25 or SX35 Virtex-4 FPGA

**Processing section**

- Up to two Xilinx Virtex-4 LX80, LX100, or LX160 FPGA
- Up to four Texas Instruments C6416 DSPs
- Up to two LYRIO add-on module sites
- cPCI, 64-bit, 66-MHz host interface for real-time data exchanges

**Audio/Video I/Os section**

- PAL/NTSC/SECAM analog video decoder
- Hardware-integrated video image scaler for various data rate emulations
- DVI transmitter
- Audio stereo codecs

### Seamless model-based design integration

Lyrtech's 4-Wave ADSs are seamlessly integrated to the Simulink model-based design environment, making it simple to develop applications and control/validate the different features of their systems in a graphical environment where programming specific processors is as easy as dragging IP blocks.

### Highly scalable solutions

By being able to expand the solutions with the help of modules, a virtually unlimited number of processors and I/O channels may be added and connected through high-speed, 8 Gbps, full-duplex links (RapidCHANNEL), making this solution ideal even for the most demanding processing tasks.



SignalMaster Quad



SignalMaster Dual



ADACMaster III module



RAVe module



Twin Tunable RF Transceiver



Twin WiMAX RF Transceiver



ADACSync

Solutions	Features	Models
SignalMaster Dual (x1) SignalMaster Dual MBDK license (x1) RAVe module (x1)	<b>Entry level</b> <b>SignalMaster Dual</b> <ul style="list-style-type: none"> <li>LX80 Virtex-4 FPGA (x1)</li> <li>1 GHz C6416 DSP (x2)</li> <li>128 MB SDRAM per DSP and FPGA</li> </ul> <b>RAVe module</b> <ul style="list-style-type: none"> <li>PAL/NTSC/SECAM analog video decoder</li> <li>DVI digital transmitter</li> <li>Audio stereo codec</li> </ul>	LSP000-636
	<b>Light</b> <b>SignalMaster Quad</b> <ul style="list-style-type: none"> <li>LX80 Virtex-4 FPGA (x2)</li> <li>1 GHz C6416 DSP (x4)</li> <li>128 MB SDRAM per DSP and FPGA</li> </ul> <b>RAVe module</b> <ul style="list-style-type: none"> <li>PAL/NTSC/SECAM analog video decoder</li> <li>DVI digital transmitter</li> <li>Audio stereo codec</li> </ul>	LSP000-624
SignalMaster Quad (x1) SignalMaster Quad MBDK license (x1) RAVe module (x1)	<b>Intermediate</b> <b>SignalMaster Quad</b> <ul style="list-style-type: none"> <li>LX100 Virtex-4 FPGA (x2)</li> <li>1 GHz C6416 DSP (x4)</li> <li>128 MB SDRAM per DSP and FPGA</li> </ul> <b>RAVe module</b> <ul style="list-style-type: none"> <li>PAL/NTSC/SECAM analog video decoder</li> <li>DVI digital transmitter</li> <li>Audio stereo codec</li> </ul>	LSP000-625
	<b>Advanced</b> <b>SignalMaster Quad</b> <ul style="list-style-type: none"> <li>LX160 Virtex-4 FPGA (x2)</li> <li>1 GHz C6416 DSP (x4)</li> <li>128 MB SDRAM per DSP and FPGA</li> </ul> <b>RAVe module</b> <ul style="list-style-type: none"> <li>PAL/NTSC/SECAM analog video decoder</li> <li>DVI digital transmitter</li> <li>Audio stereo codec</li> </ul>	LSP000-626

## Options

Components	Features	Models
ADACMaster III module ※ A maximum of two can be added to the same SignalMaster Quad and one to the SignalMaster Dual	<ul style="list-style-type: none"> <li>125-MSPS, 14-bit ADC (x2)</li> <li>500-MSPS, 16-bit, interpolating DAC (x2)</li> </ul>	LX25 FPGA—AC coupled LSP151-601 LX25 FPGA—DC coupled LSP151-602 SX35 FPGA—AC coupled LSP151-611 SX35 FPGA—DC coupled LSP151-612
ADACMaster III MBDK FPGA target license	Allows you to target the ADACMaster III's FPGA with MBDK blocks	LSP151-811
Twin Tunable RF Transceiver	<ul style="list-style-type: none"> <li>Superheterodyne receiver (IF = 30 MHz)</li> <li>Direct quadrature transmitter (IF &lt; 65 MHz)</li> <li>Software-selectable, 5 MHz or 20 MHz RX bandwidth</li> <li>SMA connectivity</li> </ul>	200–930 MHz transceiver (x2) LSP153-601 • 200–930 MHz transceiver (x1) • 1.6–2.3 GHz transceiver (x1) LSP153-611 1.6–2.3 GHz transceiver (x2) LSP153-621
Twin WiMAX RF Transceiver	<ul style="list-style-type: none"> <li>Superheterodyne receiver (IF = 44 MHz)</li> <li>Superheterodyne transmitter (IF = 18 MHz)</li> <li>Software-selectable, 7 MHz or 22 MHz RX bandwidth</li> <li>SMA connectivity</li> </ul>	2.5 GHz transceiver (x2) LSP153-602 • 2.5 GHz transceiver (x1) • 3.5 GHz transceiver (x1) LSP153-612 3.5 GHz transceiver (x2) LSP153-622
ADACSync	<ul style="list-style-type: none"> <li>Multichannel, precision, low-jitter clock generator (with GPS time base)</li> <li>Enables complete MIMO system synchronization from baseband to RF</li> </ul>	LSP000-643
cPCI chassis system + cPCI-to-PCle desktop expansion kit	<ul style="list-style-type: none"> <li>1U, 2-slot cPCI chassis</li> <li>cPCI-to-PCle desktop expansion kit</li> </ul>	LSP000-627
cPCI chassis system + cPCI-to-PCle laptop expansion kit	<ul style="list-style-type: none"> <li>1U, 2-slot cPCI chassis</li> <li>cPCI-to-PCle laptop expansion kit</li> </ul>	LSP000-628



**Kane Computing Ltd**  
 7 Theatre Court, London Road,  
 Northwich, Cheshire, CW9 5HB, UK.  
 Tel: +44(0)1606 351006  
 Fax: +44(0)1606 351007/8  
 Email: sales@kanecomputing.com  
 Web: www.kanecomputing.co.uk

With over 25 years of experience delivering advanced digital signal processing solutions to companies worldwide, Lyrtech serves customers across the Americas, Asia, and Europe. Lyrtech offers a full range of DSP-FPGA development platforms, as well as product development services. Lyrtech works in partnership with such industry leaders as Texas Instruments, The MathWorks, and Xilinx to deliver unsurpassed quality and support to its large OEM customer base, which includes many prestigious names of the consumer electronics, telecommunications, aerospace, and defense fields. In a world where digital signal processing technology is vital to network and wireless communications, audio and video processing, as well as electronic systems in all fields of technology, Lyrtech is an ideal partner.

Lyrtech products are constantly being improved; therefore, Lyrtech reserves itself the right to modify the information herein at any time and without notice.

