

# MIMO advanced development solutions

## Reference sheet

MIMO systems make up an ever increasing portion of today's wireless communication systems. In a world where constant evolution is a rule, the capacity to rapidly develop and prototype new MIMO applications is essential to profitability.

Lyrtech offers the most versatile and integrated MIMO advanced development solutions on the market, mainly because they can be largely scaled and because of their complete baseband-to-RF integration to the Simulink model-based design tools from The MathWorks.

### Fully integrated solution

Lyrtech MIMO advanced development solutions are complete baseband-to-RF solutions designed to develop MIMO and wireless applications.

### MIMO ADS families

MIMO advanced development solutions are divided into three distinct families, targeting specific areas of MIMO:

- MIMO Wi-Fi ADS (with a Quad Dual Band RF Transceiver)
- MIMO WiMAX ADS (with a Twin WiMAX RF Transceiver)
- MIMO tunable ADS (with a Twin Tunable RF Transceiver)



※ Options shown

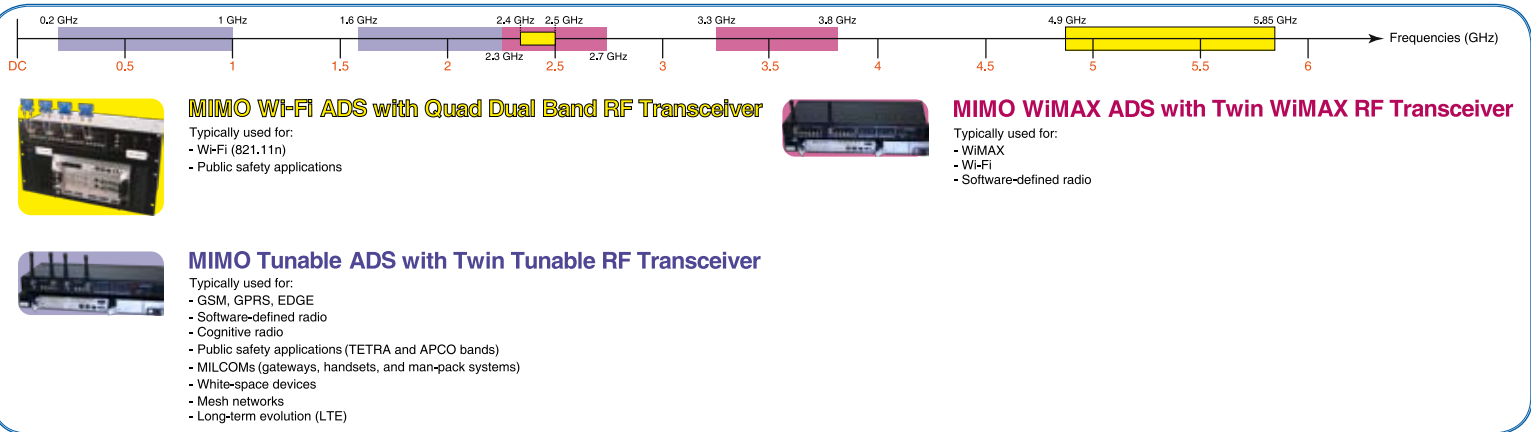

### Features

Lyrtech MIMO advanced development solutions also feature:

- Language-based and model-based design flows
- Real-time data exchange tools for the host device CPU
- Multichannel VSG and VSA recording and playback tools
- User-friendly interfaces
- Direct and remote access capabilities
- Real-time and hardware-in-the-loop co-simulation capabilities
- And more

## Scale to infinity

By being able to expand the system with the help of modules, you can add a virtually unlimited number of processors and conversion channels, all connected through high-speed, 8-Gbps, full-duplex links (RapidCHANNEL), which makes MIMO ADS ideal even for the most demanding processing or conversion tasks.

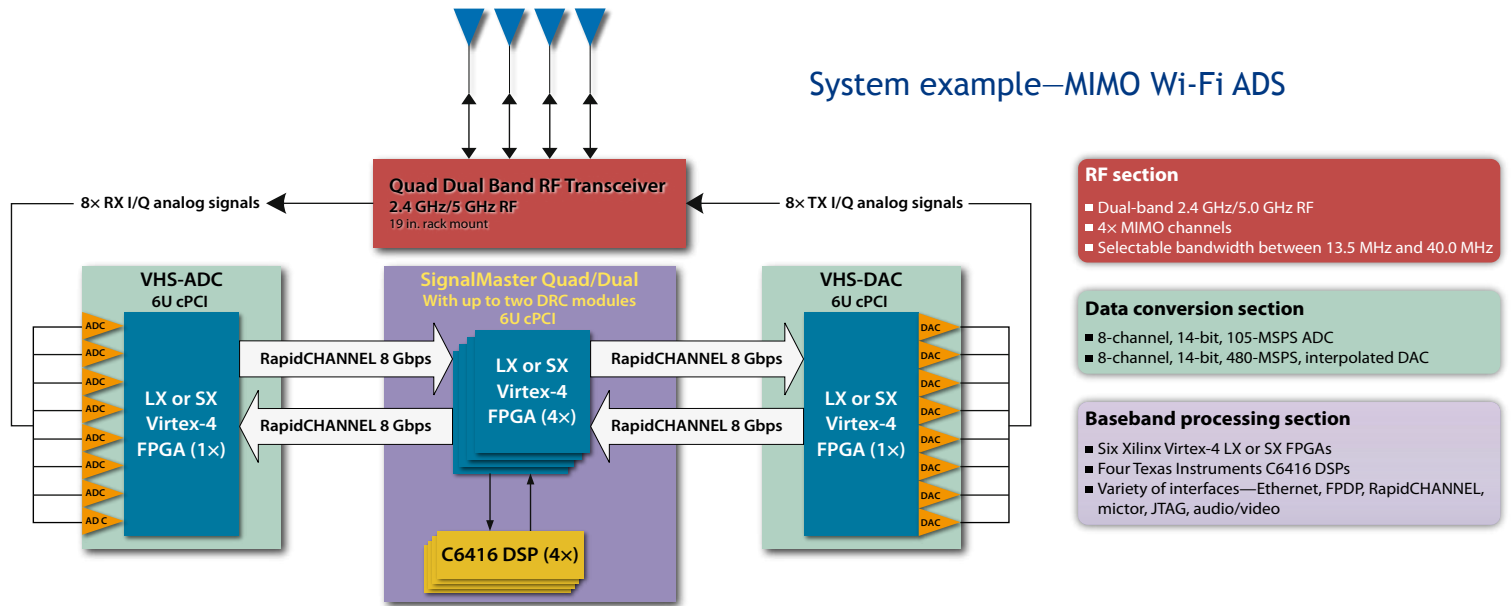

## Seamless model-based design integration

Lyrtech MIMO advanced development solutions are seamlessly integrated to the Simulink model-based design environment making it simple for users to develop applications, as well as to control and validate the different features of their systems in a graphical environment where programming specific processors is as easy as dragging IP blocks.

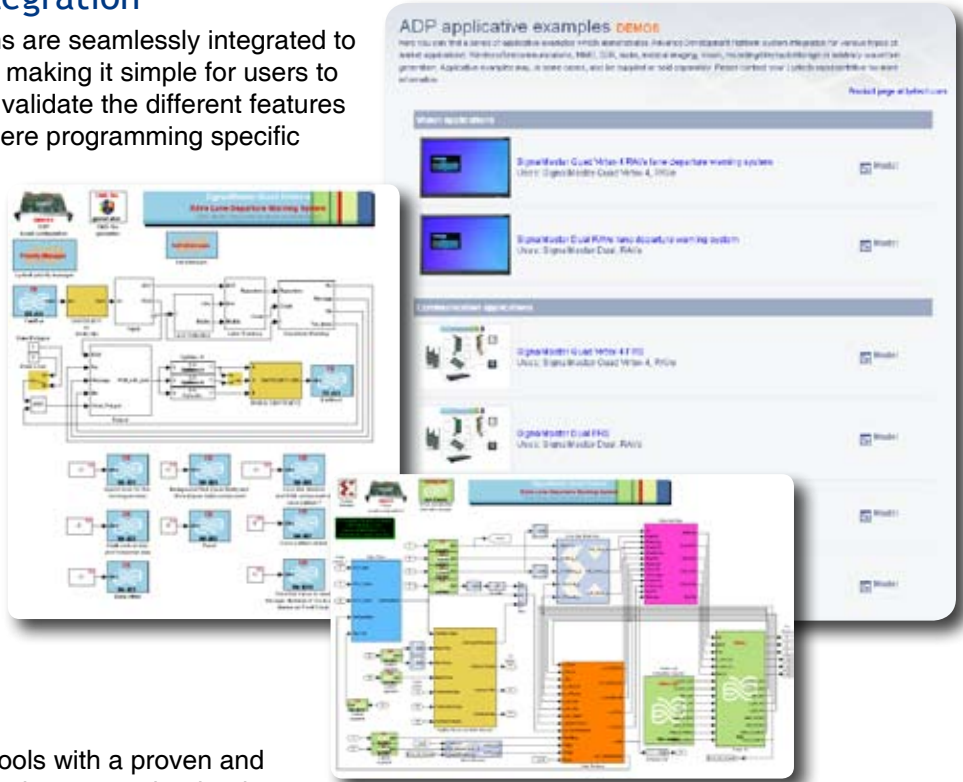

## Integrated to Diamond

Diamond from 3L enhances single-processor tools with a proven and simple multiprocessor model offering a level of abstraction that leads to efficient, coherent, reliable, and flexible systems. For details about this optional software solution, click [here](#).

**The bundle configurations presented herein are only a sample of what Lyrtech can do. Don't hesitate to contact us to discuss your specific needs.**



SignalMaster Quad



SignalMaster Dual



VHS-ADC  
VHS-DAC



ADACSync



RAVe module



ADC module  
DAC module



DRC module

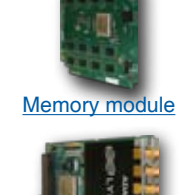

Memory module



ADACMaster III

Bundles	Features		Models	
	Common	Differentiating		
4x4 MIMO Wi-Fi	Entry level	<b>Hardware</b> <ul style="list-style-type: none"> <li>SignalMaster Dual (x1) (LX80 Virtex-4 FPGA x1, 1 GHz C6416 DSP x2)</li> </ul> <b>Software</b> <ul style="list-style-type: none"> <li>SignalMaster Dual MBDK license (x1)</li> </ul>	LSP001-607 LSP001-608 LSP000-643	
	Light	<b>Hardware</b> <ul style="list-style-type: none"> <li>VHS-ADC (x1) (SX55 Virtex-4 FPGA, DC-coupled version)</li> <li>VHS-DAC (x1) (SX55 Virtex-4 FPGA, DC-coupled version)</li> <li>Quad Dual Band RF Transceiver (x1)</li> <li>ADACSync (x1)</li> </ul> <b>Software</b> <ul style="list-style-type: none"> <li>VHS-ADC MBDK license (x1)</li> <li>VHS-DAC MBDK license (x1)</li> </ul>	<b>Hardware</b> <ul style="list-style-type: none"> <li>SignalMaster Quad (x1) (LX80 Virtex-4 FPGA x2, 1 GHz C6416 DSP x4)</li> <li>DRC module (x2) (LX25 Virtex-4 FPGA x1 each, no FPDP ports)</li> </ul> <b>Software</b> <ul style="list-style-type: none"> <li>SignalMaster Quad MBDK license (x1)</li> </ul>	LSP001-602 LSP001-607 LSP000-643
	Intermediate	<b>Hardware</b> <ul style="list-style-type: none"> <li>SignalMaster Quad (x1) (LX100 Virtex-4 FPGA x2, 1 GHz C6416 DSP x4)</li> <li>DRC module (x2) (LX25 Virtex-4 FPGA x1 each, no FPDP ports)</li> </ul> <b>Software</b> <ul style="list-style-type: none"> <li>SignalMaster Quad MBDK license (x1)</li> </ul>	<b>Hardware</b> <ul style="list-style-type: none"> <li>SignalMaster Quad (x1) (LX100 Virtex-4 FPGA x2, 1 GHz C6416 DSP x4)</li> <li>DRC module (x2) (LX25 Virtex-4 FPGA x1 each, no FPDP ports)</li> </ul> <b>Software</b> <ul style="list-style-type: none"> <li>SignalMaster Quad MBDK license (x1)</li> </ul>	LSP001-607 LSP001-610 LSP000-643
	Advanced	<b>Hardware</b> <ul style="list-style-type: none"> <li>SignalMaster Quad (x1) (LX160 Virtex-4 FPGA x2, 1 GHz C6416 DSP x4)</li> <li>DRC module (x2) (SX35 Virtex-4 FPGA x1 each, no FPDP ports)</li> </ul> <b>Software</b> <ul style="list-style-type: none"> <li>SignalMaster Quad MBDK license (x1)</li> <li>DRC onboard FPGA target MBDK license (x1)</li> </ul>	<b>Hardware</b> <ul style="list-style-type: none"> <li>SignalMaster Quad (x1) (LX160 Virtex-4 FPGA x2, 1 GHz C6416 DSP x4)</li> <li>DRC module (x2) (SX35 Virtex-4 FPGA x1 each, no FPDP ports)</li> </ul> <b>Software</b> <ul style="list-style-type: none"> <li>SignalMaster Quad MBDK license (x1)</li> <li>DRC onboard FPGA target MBDK license (x1)</li> </ul>	LSP001-607 LSP001-612 LSP000-643
2x2 MIMO WiMAX	2.5 GHz	<b>Hardware</b> <ul style="list-style-type: none"> <li>ADACMaster III (x1) (SX35 Virtex-4 FPGA, AC-coupled version)</li> <li>SignalMaster Dual (x1) (LX80 Virtex-4 FPGA x1, 1 GHz C6416 DSP x2)</li> </ul> <b>Software</b> <ul style="list-style-type: none"> <li>ADACMaster III onboard FPGA target MBDK license (x1)</li> <li>SignalMaster Dual MBDK license (x1)</li> </ul>	Twin WiMAX RF Transceiver 2.5 GHz–2.5 GHz (x1)	LSP151-611 LSP151-811 LSP155-601 LSP155-810 LSP000-647
	3.5 GHz	<b>Hardware</b> <ul style="list-style-type: none"> <li>ADACMaster III onboard FPGA target MBDK license (x1)</li> <li>SignalMaster Dual MBDK license (x1)</li> </ul>	Twin WiMAX RF Transceiver 3.5 GHz–3.5 GHz (x1)	LSP151-611 LSP151-811 LSP155-601 LSP155-810 LSP000-649
4x4 MIMO WiMAX	2.5 GHz	<b>Hardware</b> <ul style="list-style-type: none"> <li>VHS-ADC (x1) (SX55 Virtex-4 FPGA, AC-coupled version)</li> <li>VHS-DAC (x1) (SX55 Virtex-4 FPGA, AC-coupled version)</li> <li>SignalMaster Quad (x1) (LX160 Virtex-4 FPGA x2, 1 GHz C6416 DSP x2)</li> <li>DRC module (x2) (SX35 Virtex-4 FPGA x1 each, no FPDP ports)</li> <li>ADACSync (x1)</li> </ul> <b>Software</b> <ul style="list-style-type: none"> <li>VHS-ADC MBDK license (x1)</li> <li>VHS-DAC MBDK license (x1)</li> <li>SignalMaster Quad MBDK license (x1)</li> <li>DRC onboard FPGA target MBDK license (x1)</li> </ul>	Twin WiMAX RF Transceiver 2.5 GHz–2.5 GHz (x2)	LSP001-611 LSP000-647 LSP000-647 LSP000-643
	3.5 GHz	<b>Hardware</b> <ul style="list-style-type: none"> <li>VHS-ADC MBDK license (x1)</li> <li>VHS-DAC MBDK license (x1)</li> <li>SignalMaster Quad MBDK license (x1)</li> <li>DRC onboard FPGA target MBDK license (x1)</li> </ul>	Twin WiMAX RF Transceiver 3.5 GHz–3.5 GHz (x2)	LSP001-611 LSP000-649 LSP000-649 LSP000-643
Dual band 2x2 MIMO WiMAX	2.5 GHz-3.5 GHz	<b>Hardware</b> <ul style="list-style-type: none"> <li>ADACMaster III (x2) (SX35 Virtex-4 FPGA, AC-coupled version)</li> <li>SignalMaster Quad (x1) (LX160 Virtex-4 FPGA x2, 1 GHz C6416 DSP x4)</li> <li>Twin WiMAX RF Transceiver 2.5 GHz–2.5 GHz (x1)</li> <li>Twin WiMAX RF Transceiver 3.5 GHz–3.5 GHz (x1)</li> <li>ADACSync (x1)</li> </ul> <b>Software</b> <ul style="list-style-type: none"> <li>ADACMaster III onboard FPGA target MBDK license (x1)</li> <li>SignalMaster Quad MBDK license (x1)</li> </ul>		LSP140-613 LSP140-810 LSP151-611 LSP151-611 LSP151-811 LSP000-643 LSP000-647 LSP000-649

