

# Twin Tunable RF Transceiver

## 0.2-1.0 GHz/1.6-2.3 GHz RF front end

The Twin Tunable RF Transceiver is a 19-inch, rack-mount, two-channel, tunable RF, analog front end designed to couple with Lyrtech advanced development platforms. The transceiver covers frequencies in the low-band (0.2–1.0 GHz) and high-band (1.6–2.3 GHz) ranges and, when it is combined with the Lyrtech [SignalMaster Dual](#) or [SignalMaster Quad](#) and the [ADACMaster III](#) add-on module (high-speed AD/DA board), the whole forms a complete and integrated hardware and software development solution for a wide range of software-defined radio (SDR) applications.



### AT A GLANCE

- Rack-mount, two-channel, 0.2–1.0 GHz/1.6–2.3 GHz, RF analog front end
- Superheterodyne receiver (IF = 30 MHz)
- Direct quadrature transmitter (IF < 65 MHz)
- Full-duplex transceiver—allows TDD and FDD
- Plug and Play with Lyrtech DSP–FPGA advanced development platforms
- Software-selectable 5 MHz or 20 MHz RX bandwidths
- Up to 80 dB of isolation between TX and RX

### Applications

The following are only a few of the applications where the Twin Tunable RF Transceiver is at its best:

#### Military

Military applications such as tactical military communications (MILCOM), military communications gateways, handsets and man-pack systems, smart and cognitive radio systems, and vehicular systems are prime candidates for SDR development.

#### Public safety

The Twin Tunable RF Transceiver allows public safety applications such as TETRA and APCO band communications, vehicular systems, transponders, and broadband data systems.

#### Commercial

White space devices, broadband data systems, vehicular systems, femto and pico base stations, cognitive radio networks, and smart radios are all applications that can be developed with the Twin Tunable RF Transceiver. Potential waveforms are quad band GSM/GPRS/EDGE, DECT, PHS, W-CDMA, HSDPA/HSUPA, TD-SCDMA, IS-95, and CDMA2000.

### Software tools

The Twin Tunable RF Transceiver benefits from:

- Boards drivers and application examples supplied with the SignalMaster Quad and SignalMaster Dual board software development kits (BSDKs) and model-based design blocksets with the model-based design kits (MBDKs). (The target FPGA software for the ADACMaster III is also recommended to benefit from the module's real-time FPGA gain control parameters, useful in transceiver applications.)
- The Twin Tunable RF Transceiver can also be used stand alone with the optional USB-to-GPIO-32 adapter. This mode of operations can be useful for troubleshooting.

### Available hardware options

- One low-band channel, one high-band channel
- Two low-band channels (used individually or for 2x2 MIMO)
- Two high-band channels (used individually or for 2x2 MIMO)

# Specifications

General	<ul style="list-style-type: none"> <li>• 44.45 mm × 431.80 mm × 203.20 mm (1.75 in. × 17.00 in. × 8.00 in.)</li> <li>• 19-in., 1U rack-mount case</li> <li>• Supply voltage: 12 V</li> <li>• Supply current: 1.5 A</li> <li>• Power consumption: 17 W</li> <li>• Up to 80 dB of isolation between TX and RX</li> <li>• 3-dBm transmission power at P-1 dB</li> <li>• 2x2 MIMO mode clock synchronization for twin low-band channels or twin high-band channels</li> <li>• GPIO-32 control interface (SPI ports, others)</li> <li>• Supports configuration from the ADACMaster III's GPIO-32 port or the USB-2-GPIO-32 adapter</li> <li>• Full-duplex transceivers (separate RX and TX antennas)</li> <li>• Software-selectable reception bandwidths: 5 MHz or 20 MHz</li> </ul>
Low-band channel	<p><b>RF frequency range</b></p> <ul style="list-style-type: none"> <li>• TX: 0.2 GHz to 1.0 GHz</li> <li>• RX: 0.2 GHz to 1.0 GHz</li> </ul> <p><b>RF input</b></p> <ul style="list-style-type: none"> <li>• Gain: 50 dB (RX selectable filter: 20 MHz)</li> <li>• Gain: 46 dB (RX selectable filter: 5 MHz)</li> <li>• Noise figure : 5 dB</li> <li>• Phase noise at 10 kHz from carrier: -75 dBc/Hz (RF: 425 MHz)</li> <li>• Phase noise at 100 kHz from carrier: -103 dBc/Hz (RF: 425 MHz)</li> <li>• Minimum detectable signal: -102 dBm (bandwidth: 5 MHz)</li> </ul> <p><b>RF output</b></p> <ul style="list-style-type: none"> <li>• Carrier suppression: -55 dBc</li> <li>• Sideband suppression: -37 dBc</li> <li>• Phase noise at 10 kHz from carrier: -83 dBc/Hz (RF: 425 MHz)</li> <li>• Phase noise at 100 kHz from carrier: -109 dBc/Hz (RF: 425 MHz)</li> <li>• Gain: 8 dB</li> <li>• IP3 output: 25 dBm</li> </ul> <p>• RX/TX IF center frequency: 30 MHz</p> <p>• Reference clock input: 4 MHz to 100 MHz, -20 dBm to 10 dBm</p> <p>• Reference clock output: 10 MHz, 10 dBm</p>
High-band channel	<p><b>RF frequency range</b></p> <ul style="list-style-type: none"> <li>• TX: 1.6 GHz to 2.5 GHz</li> <li>• RX: 1.6 GHz to 2.3 GHz</li> </ul> <p><b>RF input</b></p> <ul style="list-style-type: none"> <li>• Gain: 42 dB (RX selectable filter: 20 MHz)</li> <li>• Gain: 40 dB (RX selectable filter: 5 MHz)</li> <li>• Noise figure : 6 dB</li> <li>• Phase noise at 10 kHz from carrier: -75 dBc/Hz (RF: 2 GHz)</li> <li>• Phase noise at 100 kHz from carrier: -103 dBc/Hz (RF: 2 GHz)</li> <li>• Minimum detectable signal : -101 dBm (5 MHz bandwidth filter)</li> </ul> <p><b>RF output</b></p> <ul style="list-style-type: none"> <li>• Carrier suppression: -55 dBc</li> <li>• Sideband suppression: -37 dBc</li> <li>• Phase noise at 10 kHz from carrier: -80 dBc/Hz (RF: 2 GHz)</li> <li>• Phase noise at 100 kHz from carrier: -109 dBc/Hz (RF: 2 GHz)</li> <li>• Gain: 8 dB</li> <li>• IP3 output: 23 dBm</li> </ul> <p>• RX/TX IF center frequency: 30 MHz</p> <p>• Reference clock input: 4 MHz to 100 MHz, -20 dBm to 10 dBm</p> <p>• Reference clock output: 10 MHz, 10 dBm</p>

# Block diagrams

## Low-band channel

### Superheterodyne receiver

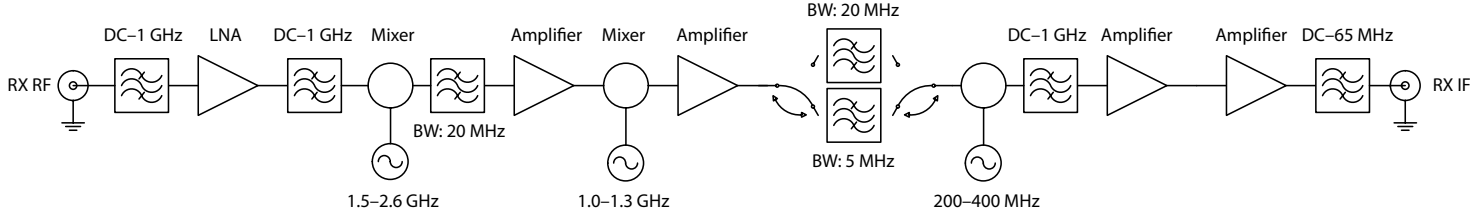

### Supply and control

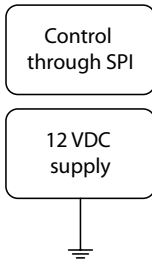

### Transmitter

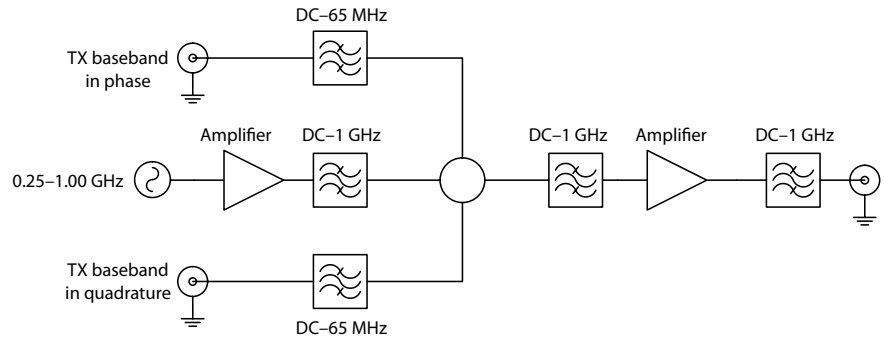

## High-band channel

### Superheterodyne receiver

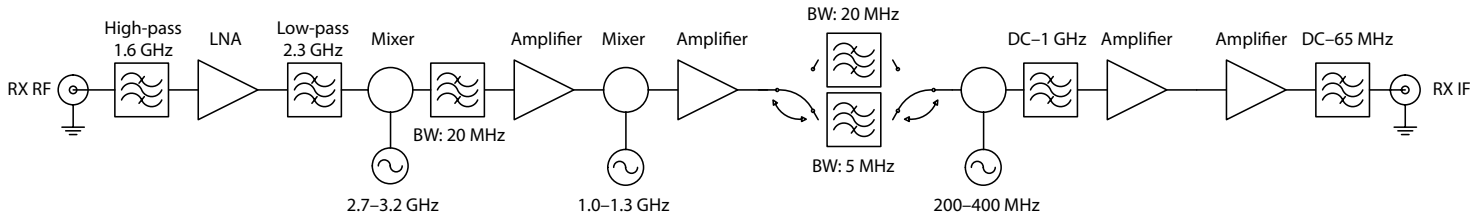

### Supply and control

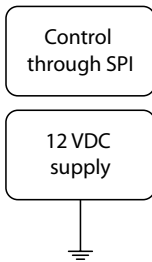

### Transmitter

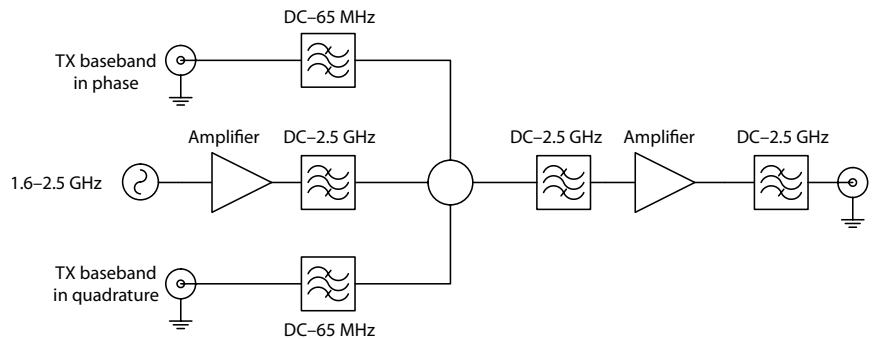



**Kane Computing Ltd**  
**7 Theatre Court, London Road,**  
**Northwich, Cheshire, CW9 5HB, UK.**  
**Tel: +44(0)1606 351006**  
**Fax: +44(0)1606 351007/8**  
**Email: [sales@kanecomputing.com](mailto:sales@kanecomputing.com)**  
**Web: [www.kanecomputing.co.uk](http://www.kanecomputing.co.uk)**

With over 25 years of experience delivering advanced digital signal processing solutions to companies worldwide, Lyrtech serves customers across the Americas, Asia, and Europe. Lyrtech offers a full range of DSP-FPGA development platforms, as well as product development services. Lyrtech works in partnership with such industry leaders as Texas Instruments, The MathWorks, and Xilinx to deliver unsurpassed quality and support to its large OEM customer base, which includes many prestigious names of the consumer electronics, telecommunications, aerospace, and defense fields. In a world where digital signal processing technology is vital to network and wireless communications, audio and video processing, as well as electronic systems in all fields of technology, Lyrtech is an ideal partner.

Lyrtech products are constantly being improved; therefore, Lyrtech reserves itself the right to modify the information herein at any time and without notice.

2009-06

Lyrtech Inc. All rights reserved.

