

Twin WiMAX RF Transceiver

2.5 GHz/3.5 GHz RF front end

The Twin WiMAX RF Transceiver is a 19-inch, rack-mount, two-channel, WiMAX RF analog front end designed to work with Lyrtech advanced development platforms.

The transceiver can cover the 2.5 GHz WiMAX band (2.3–2.7 GHz), the 3.5 GHz WiMAX band (3.3–3.8 GHz), or both bands. When it is combined with Lyrtech's



AT A GLANCE

- Rack-mounted, two-channel RF analog front end
- Low-band RF range: 2.3–2.7 GHz
- High-band RF range: 3.3–3.8 GHz
- Superheterodyne receiver (IF baseband = 44 MHz)
- Superheterodyne transmitter (IF baseband = 18 MHz)
- Half-duplex transceiver—allows TDD
- Plug and Play with Lyrtech advanced development platforms
- 7 MHz and 22 MHz software-selectable RX bandwidths
- RF transmission power up to 30 dBm
- Controllable RX gain up to 15 dB (or 10-dB attenuation) for AGC implementation
- Dual SISO or 2x2 MIMO modes (4x4 MIMO also possible by interconnecting units)

Software tools

The Twin WiMAX RF Transceiver benefits from:

- Boards drivers, model-based design blocksets and application examples supplied with the SignalMaster Quad and SignalMaster Dual board software development kits (BSDK) and model-based design kits (MBDK). (The software allowing to target the FPGA of the ADACMaster III is also recommended to benefit from the real-time FPGA gain control parameters, useful in transceiver applications.) The software supplied with VHS-ADCs and VHS-DACs also allow you to control two transceivers connected in a 4x4 MIMO configuration.
- The Twin WiMAX RF Transceiver can also be used stand alone through the optional USB-to-GPIO-32 adapter—a mode of operations that can prove useful for troubleshooting.

Available hardware options

- One low-band channel (2.5 GHz), one high-band channel (3.5 GHz)
- Two low-band (2.5 GHz) channels (used individually or for 2x2 MIMO)
- Two high-band (3.5 GHz) channels (used individually or for 2x2 MIMO)

Don't hesitate to write to info@lyrtech.com if you need different frequency bands or have different frequency requirements.

DSP–FPGA-based [SignalMaster Dual](#), [SignalMaster Quad](#), and [ADACMaster III](#) add-on module (high-speed, AD/DA board), the Twin WiMAX RF Transceiver becomes a complete and integrated hardware/software development solution for advanced WiMAX development. In the 2.5 GHz band, the front end covers all the ISM bands and makes all sorts of Wi-Fi (b, g, n) applications possible.

Applications

MAN/WAN (WiMAX)

The Twin WiMAX RF Transceiver allows targeting WiMAX applications in the 2.5 GHz and 3.5 GHz bands.

WLAN (Wi-Fi)

WLAN applications in all the ISM bands can be developed with the Twin WiMAX RF Transceiver (Wi-Fi b, g, or n).

Software-defined radio

When it is combined with Lyrtech's powerful SignalMaster Quad or SignalMaster Dual, the Twin WiMAX RF Transceiver can be used to develop DSP–FPGA-based software-defined radio applications within the 2.5 GHz and 3.5 GHz ranges.

Specifications

General	44.45 mm × 431.80 mm × 203.20 mm (1.75 in. × 17.00 in. × 8.00 in.)
	19-in., 1U rack-mount case
	Supply voltage: 12 V
	Supply current: 1.1 A
	Power consumption: 13.2 W
	2x2 mode MIMO clock synchronization for twin 2.5 GHz channels or twin 3.5 GHz channels
	GPIO-32 control interface (SPI ports, others)
	Supports configuration from the ADACMaster III's GPIO-32 port or the USB-2-GPIO-32 adapter
	Half-duplex transceiver (shared RX/TX antenna)
	Software-selectable reception bandwidth: 7.0 MHz and 22 MHz
2.5 GHz band channels	RF frequency range: 2.3 GHz to 2.7 GHz
	RF input <ul style="list-style-type: none"> Gain: 20 dB to 100 dB (BW:7 MHz) Gain: 30 dB to 110 dB (BW:22 MHz) Noise: 7 dB Phase noise at 100 kHz from carrier: -90 dBc/Hz (RF: 2.5 GHz) Phase noise at 1 MHz from carrier: -92 dBc/Hz (RF: 2.5 GHz) Minimum detectable signal: -98 dBm (BW: 7 MHz) Minimum detectable signal: -94 dBm (BW: 22 MHz) RX IF baseband center frequency: 44 MHz RF resolution: 1 MHz
	RF output <ul style="list-style-type: none"> Phase noise at 100 kHz from carrier: -89 dBc/Hz (RF: 2.5 GHz) Phase noise at 1 MHz from carrier: -112 dBc/Hz (RF: 2.5 GHz) Gain: -2 dB to 30 dB IP3 output: 10 dBm TX IF frequency range: 13 MHz to 23 MHz
	Reference clock input (36 MHz): 12 dBm to 17 dBm
	Reference clock output (36 MHz): 14 dBm
3.5 GHz band channels	RF frequency range: 3.3 GHz to 3.8 GHz
	RF input <ul style="list-style-type: none"> Gain: 40 dB to 115 dB (BW: 7 MHz) Gain: 30 dB to 105 dB (BW: 22 MHz) Noise: 5 dB Phase noise at 100 kHz from carrier: -90 dBc/Hz (RF: 3.5 GHz) Phase noise at 1 MHz from carrier: -92 dBc/Hz (RF: 3.5 GHz) Minimum detectable signal: 100 dBm (BW: 7 MHz) Minimum detectable signal: -95 dBm (BW: 22 MHz) RX IF baseband center frequency: 44 MHz RF resolution: 1 MHz
	RF output <ul style="list-style-type: none"> Phase noise at 100 kHz from carrier: -89 dBc/Hz (RF: 3.5 GHz) Phase noise at 1 MHz from carrier: -112 dBc/Hz (RF: 3.5 GHz) Gain: -5 dB to 27 dB IP3 output: 17 dBm TX IF frequency range: 13 MHz to 23 MHz
	Reference clock input (36 MHz): 12 dBm to 20 dBm
	Reference clock output (36 MHz): 15 dBm

Block diagrams

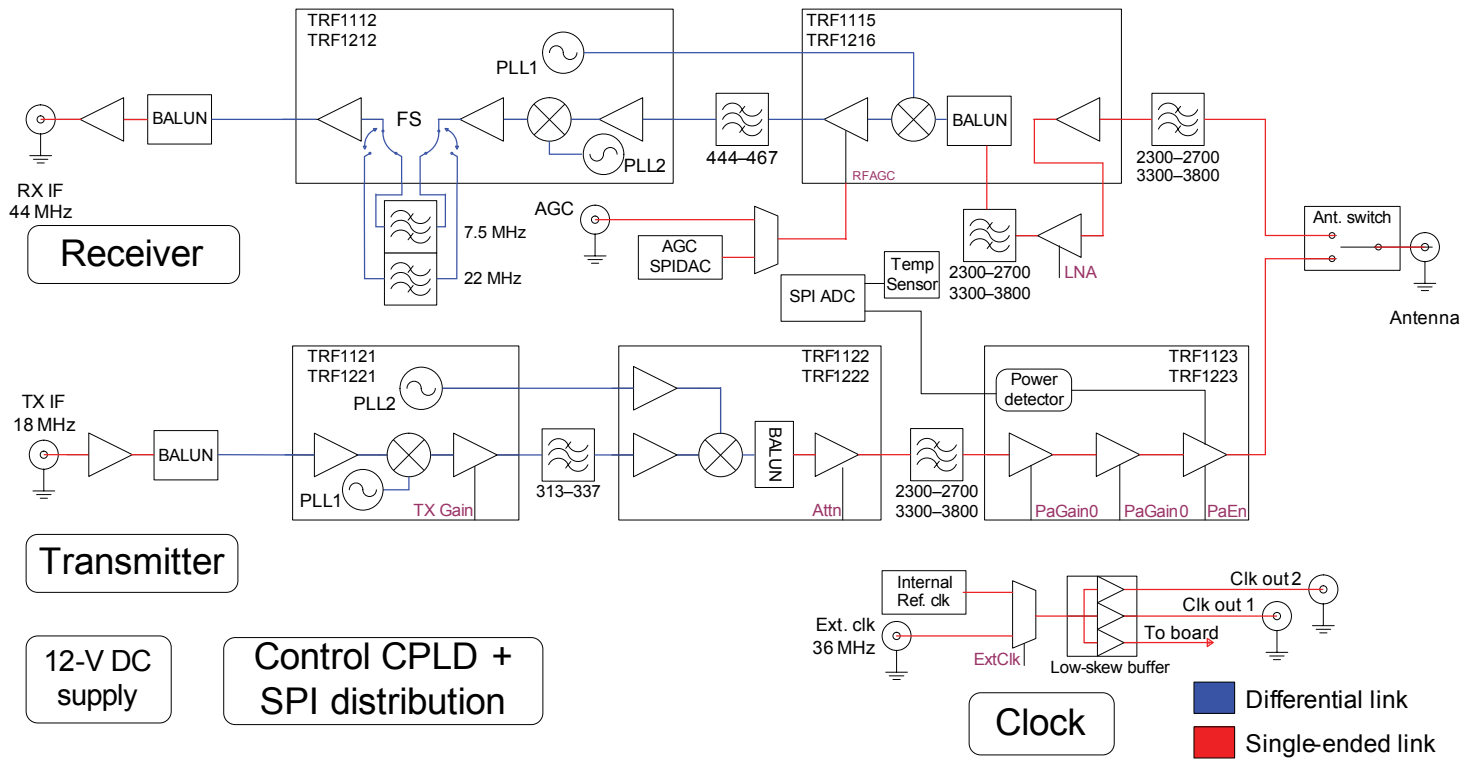



Kane Computing Ltd
7 Theatre Court, London Road,
Northwich, Cheshire, CW9 5HB, UK.
Tel: +44(0)1606 351006
Fax: +44(0)1606 351007/8
Email: sales@kanecomputing.com
Web: www.kanecomputing.co.uk

With over 25 years of experience delivering advanced digital signal processing solutions to companies worldwide, Lyrtech serves customers across the Americas, Asia, and Europe. Lyrtech offers a full range of DSP-FPGA development platforms, as well as product development services. Lyrtech works in partnership with such industry leaders as Texas Instruments, The MathWorks, and Xilinx to deliver unsurpassed quality and support to its large OEM customer base, which includes many prestigious names of the consumer electronics, telecommunications, aerospace, and defense fields. In a world where digital signal processing technology is vital to network and wireless communications, audio and video processing, as well as electronic systems in all fields of technology, Lyrtech is an ideal partner.

Lyrtech products are constantly being improved; therefore, Lyrtech reserves itself the right to modify the information herein at any time and without notice.

2009-06

Lyrtech Inc. All rights reserved.

