

## picasso™ CL series



### Key Features:

- digital CameraLink interface
- available in 3 form factors:
  - standard PCI
  - Compact PCI
  - PC/104 *plus*
- support 8 to 16 bits data input formats
- sampling rates up to 40 MHz
- image size:
  - up to 4095 pixels/line (up to 8190 pixels/line if 8 bit/pix)
  - 4095 lines/frame
- one or two taps
- programmable exposure time
- supports area and linescan cameras
- on board UART for bidirectional serial camera communication
- two RS-232 full duplex communication channels
- two digital inputs and two digital outputs (optical isolated)
- software support for several (real time) operating systems

### General

With the picasso™ CL serie high speed digital video transmission is possible. The picasso™ PCI-CL framegrabber is a high performance 'plug and play' PC-card for the PCI-bus and provides high-resolution image capture for digital video cameras. It enables each standard PCI system to capture and store single images for image processing or full frame display of real time digital video in a window. This model operates as a PCI-bus master and it transfers images directly to the system memory without impacting the processor.

## Architecture

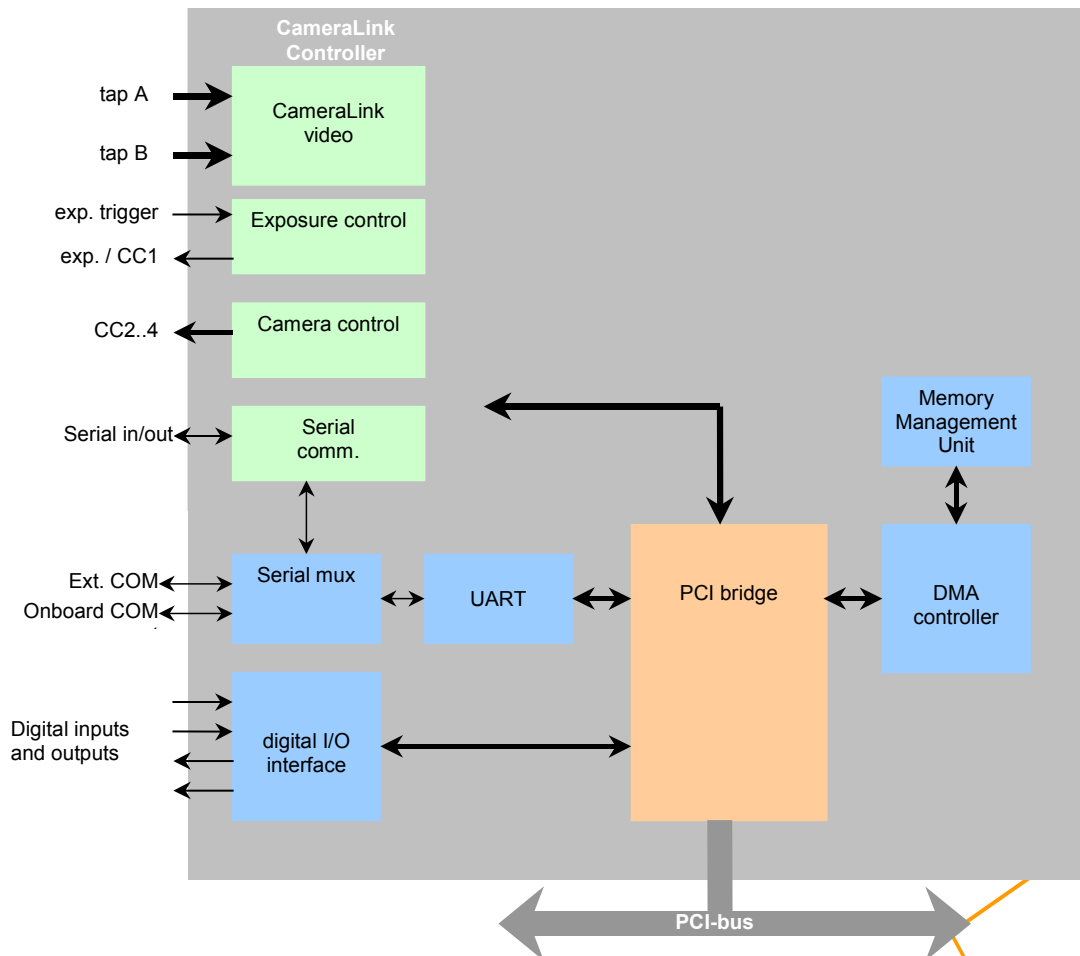

## Detailed Information

### Video Inputs

The picasso™ CL-serie accepts video sources compliant with CameraLink video standard from area scan and line scan camera's. The image resolution is up to 8190 pixels x 4095 lines in 8 bit/pixel mode. In other modes the resolution is 4095 pixels x 4095 lines.

The picasso™ accepts 8,10, 12, 14 or 16 bits single channel cameras or 8 bit dual channel cameras (two tap camera).

### Camera Control Signals

The framegrabber has four CameraLink Control signals (CC1..CC4). These outputs are software controlled. CC1 is used for exposure the camera

### Exposure

The exposure output of the CameraLink can be used in two ways:

- Software triggered.
- Hardware triggered

### Software triggered exposure

With software functions it is possible to generate a exposure signal to the camera.

The exposure time is programmable between 6.375 µs and 417ms.

The signal is low or high active.

### Hardware triggered exposure

For the hardware trigger mode you should use the exposure header. In this mode the TTL signal is given on the exposure input.

The CameraLink exposure output depends on software controlled settings:

- exposure output follows input
- exposure output is inverted input
- after a falling or rising edge of the input, the exposure output is low or high for 'exposure time'

The exposure time is programmable between 6.375µs and 417ms.

*Exposure-time: Refers to the period during which the image sensor of a camera is exposed to the light. As the length of this period increases, so does the image brightness.*

### RS-232 - CameraLink

Most CameraLink cameras are controlled by RS-232 via the CameraLink cable. The picasso™ CL-serie has the possibility to interface RS-232 signals to the CameraLink signals.

There are two modes:

- use the COM-port of the framegrabber to communicate with the camera
- use the on board UART of the framegrabber to communicate with the camera

#### RS-232 via COM-port

All RS-232 data transmitted to the COM port of the picasso™ will be converted to CameraLink signals and will be transmitted to the camera. This data path is bi directional, so CameraLink data from the camera are converted to RS-232 signals, which are transmitted to the framegrabbers COM port.

In the next figure the RS-232 are coming from the COM-port of the host (computer).

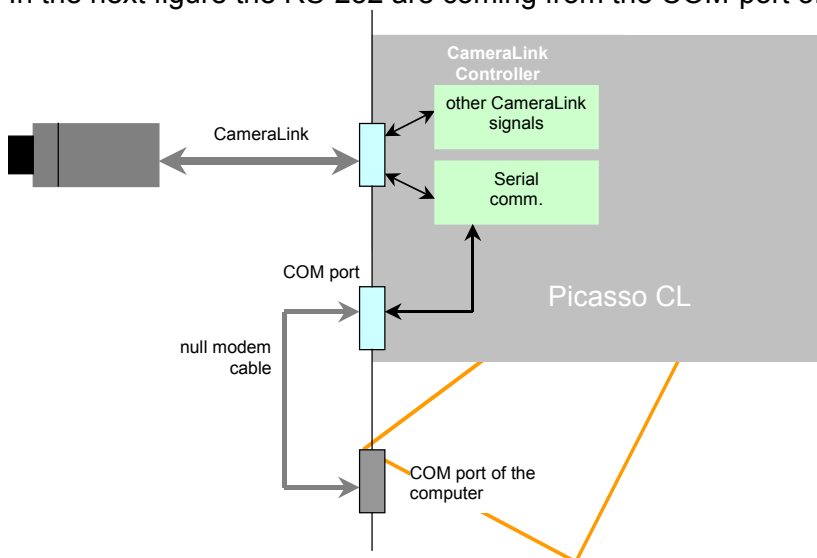

RS-232 by the on board UART

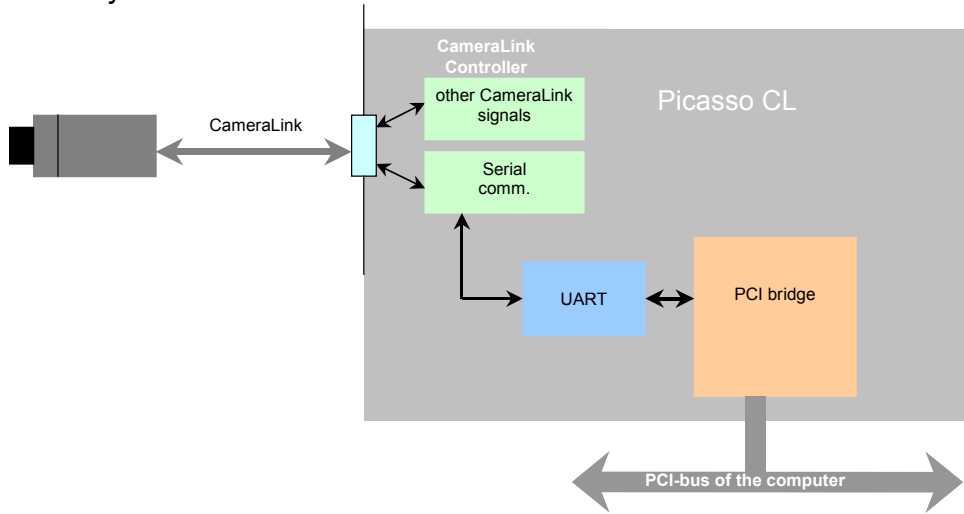

The Serial data to the camera is controlled by an on board UART. This UART is software controlled. If you want to write data to the camera you call the UART's write function. The data will be converted to CameraLink signals and transmitted to the camera. It is also possible to receive data from the camera. The data from the camera can be read by reading data from the on board UART.

## Technical Specifications

<b>picasso™ CL serie</b>			
	standard PCI	Compact PCI	PC/104 plus
PCI Bus	PCI 2.1 32-bit PCI interface PCI bus master up to 132 Mbytes/sec. Supports zero wait state burst transfers Plug and play, no jumpers	Compact PCI 2.0	PC/104plus 1.0 3.3V or 5V
Video input taps	CameraLink one ore two taps		
Pixel formats	one tap: 8..16 bits two taps: 2 x 8 bits		
Video resolution	4095 pixels per line (8190 pixel per line if 8 bit/pixel) 4095 lines per frame		
Pixel clock	up to 40 MHz		
Capture format	Y8 Y16 RGB24 for color camera's with Bayer filter <i>needs postprocessing</i>		
Exposure timer	programmable between 6.375 µs and 417 ms		
Exposure input trigger	TTL signal		
CameraLink output Control signals	CC1, CC2, CC3 and CC4 CC1 is used for exposure		
Digital I/O	2 digital inputs 2 digital outputs TTL compatible optical isolated (on PCI/cPCI models) inputs can be programmed as interrupt or as capture start 5V, 100 mA, 10kHz		
CameraLink Connector	MDR 26-pin female		
RS-232 connectors	A: SUB-D9 on the bracket ( <i>only PCI and cPCI versions</i> ) B: 10-pins header on PCB		
Digital I/O connector	10-pins header on PCB		
Exposure input connector	3-pins header on PCB		combined with Digital I/O connector
Dimensions (mm)	106 x 175	100 x 1603U Eurocard	90 x 96
Power consumption	5.75 W		
Operating temperature	0° C to 70° C		
Operating Systems	Windows 95/ 98/ Me/ NT/ 2000/ XP Linux Solaris 8 (x86 and SPARC)		
RT Operating Systems	RTLinux, QNX4 and QNX6		
Software	Windows: Visual C++, Borland C (ANSI C compilers) Visual Basic, Delphi Linux, Solaris and QNX6: (GNU) C compiler QNX4: Watcom C compiler		

## Options

### **Software**

Windows 95 Software Development Kit  
Windows 98 Software Development Kit  
Windows Me Software Development Kit  
Windows NT Software Development Kit  
Windows 2000 Software Development Kit  
Windows XP Software Development Kit

Linux Software Development Kit  
Realtime Linux Software Development Kit

Solaris 8 (SPARC) Software Development Kit  
Solaris 8 (i86) Software Development Kit

QNX4 Software Development Kit  
QNX6 (x86) Software Development Kit

### **Cable sets**

CameraLink cable, 1 meter  
CameraLink cable, 2 meter

### **Miscellaneous**

PC/104 stack through connector