

# PM50

*Version 2.0*

**Power Module  
for DC, Brushless DC  
and AC Motors**

TECHNOSOFT



**DSP Motion Solutions**

## User Manual

**TECHNOSOFT**  
**DSP Motion Solutions**

**PM50 v2.0**  
***User Manual***

**P091.058.V20.UM.1001**  
**October 2001**

**Technosoft S.A.**  
Rue des Courtils 8A  
CH 2035 Corcelles  
Switzerland  
Tel: +(41) 32 732 5500  
FAX: +(41) 32 732 5504  
E-mail: [contact@technosoft.ch](mailto:contact@technosoft.ch)  
<http://www.technosoft.ch>

---

## Read This First

### *About This Manual*

This book describes the power module **PM50 version 2.0**. The PM50 v2.0 is a 75W-power module that can be used to drive DC brush, brushless DC and AC motors. Due to the MC-Bus compatible interface for the control unit, the PM50 v2.0 can be easily connected with all Technosoft DSP-based modules equipped with MC-Bus interface.

### *Information about Cautions*

This book may contain cautions.

**CAUTION ! This is an example of a warning statement.  
A warning statement describes a situation that could potentially cause harm to you or to the PM50 v2.0 power module**

### *If you Need Assistance ...*

| <b>If you want to ...</b>   | <b>Contact Technosoft at ...</b>   |
|---|--|
| Visit Technosoft online   | World Wide Web: <a href="http://www.technosoft.ch">http://www.technosoft.ch</a>  |
| Receive general information or assistance (see Note)                          | World Wide Web: <a href="http://www.technosoft.ch">http://www.technosoft.ch</a><br>Email: <a href="mailto:contact@technosoft.ch">contact@technosoft.ch</a> |
| Ask questions about product operation or report suspected problems (see Note) | FAX: (41) 91 976 0504<br>Email: <a href="mailto:hotline@technosoft.ch">hotline@technosoft.ch</a>   |
| Make suggestions about or report errors in documentation (see Note)           | Mail: Technosoft SA<br>Via Aldesago 1<br>CH 6977 Ruvigliana<br>Switzerland   |

**Note:** You need to register your PM50 v2.0 system in order to get free assistance and support.

---

### ***Important Notice***

Technosoft, S.A. reserves the right to make changes to its products or to discontinue any product or service without notice, and advises its customers to obtain the latest version of relevant information to verify, before placing orders, that the information being relied on is current.

Technosoft, S.A. warrants performance of its products and related software to current specifications in accordance with Technosoft 's standard warranty. Testing and other quality control techniques are utilized to the extent deemed necessary to support this warranty.

Please be aware that the products described herein are not intended for use in life-support appliances, devices, or systems. Technosoft, S.A. does not warrant nor is liable for the product described herein to be used in other than a development environment. Technosoft, S.A. assumes no liability for applications assistance, customer product design, software performance, or infringement of patents or services described herein. Nor does Technosoft warrant or represent any license, either express or implied, is granted under any patent right, copyright, or other intellectual property right of Technosoft, S.A. covering or relating to any combination, machine, or process in which such Power Module development products or services might be or are used.

### ***FCC Warning***

This equipment is intended for use in a laboratory test environment only. It generates, uses, and can radiate radio frequency energy and has not been tested for compliance with the limits of computing devices pursuant to subpart J of part 15 of FCC rules, which are designed to provide reasonable protection against radio frequency interference. Operation of this equipment in other environments may cause interference with radio communications, in which case the user at his own expense will be required to take whatever measures may be required to correct this interference.

## Contents

### 1 Introduction

- 1.1 PM50 v2.0 Overview
- 1.2 Block Diagram
- 1.3 Key Features

### 2 PM50 v2.0 Operation

- 2.1 Board Layout
- 2.2 Power Supply
  - 2.2.1 J5 – Supply Connector
- 2.3 Power Stage Module
  - 2.3.1 3-phase Inverter Command
  - 2.3.2 Protections. Error Signal
  - 2.3.3 Current Measurement Interface
  - 2.3.4 Motor Supply / DC-bus Voltage Measurement
  - 2.3.5 J3 – Motor and Hall Sensors Connector
  - 2.3.6 J6 – Encoder Connector
- 2.4 Communication
  - 2.4.1 J4 – RS-232 Connector
- 2.5 Control Unit Interface (MC-Bus)
  - 2.5.1 J1, J2 – MC-Bus Connectors
- 2.6 JP1 - Jumper

### Appendices

- A. PM50 v2.0 Electrical Specifications
- B. MC-Bus Pin Correspondence with IMMC240 v3.0 and MCSK v1.0
- C. MC-Bus Pin Correspondence with MSK243 v1.1

---

This page is empty

## 1. Introduction

This chapter provides a general description of the PM50 v2.0 power module along with a block diagram and the key features

### Contents

1.1. PM50 v2.0 Overview

1.2. Block Diagram

1.3. Key Features

### **1.1. PM50 v2.0 Overview**

The PM50 v2.0 is a 75W MC-Bus compatible power module, which combined with a control unit, allows to drive the following categories of motors:

- brushless DC motors
- permanent magnet synchronous motors (PMSM)
- DC brush motors

The PM50 v2.0 includes the following main components:

- 3-phase MOSFET inverter: 36 V, 2.1 A, up to 100 kHz switching frequency
- 3 currents feedback, measured from the low-side legs of the inverter
- DC-bus voltage feedback
- Hall sensors inputs
- Incremental encoder port
- RS-232 serial communication connector
- Logical supply:  $5V_{DC}$
- Motor supply:  $12 - 36V_{DC}$
- Protections to short-circuit, over-current, over-voltage and accidental logic supply shutdown
- Standard MC-Bus interface with the control unit

Through the MC-bus interface the control unit can:

- Command each of the 6 MOSFET transistors of the inverter
- Receive a power stage error signal when the protections are triggered and the inverter transistors are turned-off
- Read the motor currents and the DC-bus voltage
- Read the motor Hall signals
- Read the encoder quadrature signals A, B and the Index
- Control the RS-232 serial communication

At MC-bus level, the MOSFET transistor commands and the power stage error signal are TTL/CMOS compatible. Bipolar signals, as motor currents, are applied with half scale offset, e.g. with zero value at 2.5V.

Due to the MC-bus compatibility, the PM50 v2.0 can be easily connected with any Technosoft DSP-based control unit.

### **1.2. Block Diagram**

Figure 1.1 presents the block diagram of the PM50 v2.0 including the main components.

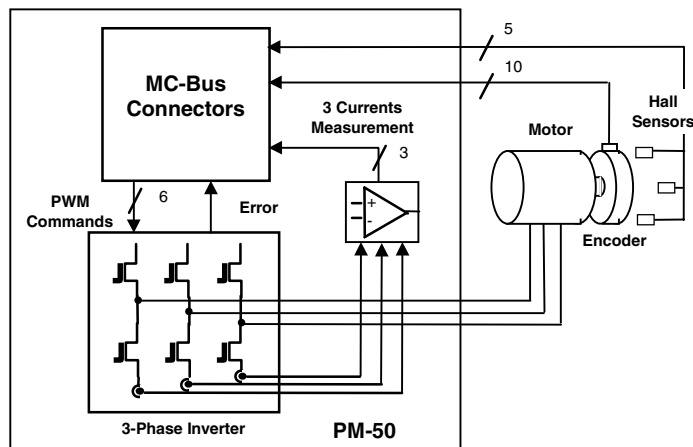

**Figure 1.1. PM50 v2.0 Block Diagram**

### 1.3. Key Features

- MC-bus compatible power module, easy connectable with any Technosoft DSP-based control module
- Suitable to drive brushless DC, brushless AC (PMSM) and DC motors
- Logic supply:  $+5V_{DC}$  ( $\pm 5\%$ )
- Motor supply:  $12 - 36V_{DC}$
- Nominal output power: 75W
- Nominal current: 2.1A
- Peak current: 6.33A, for 0.1s
- Output voltage:  $0 \div 36 V_{rms}$
- 3-phase MOSFET inverter with switching frequency up to 100 kHz
- Protection to short-circuit (phase-phase), over-current and over-voltage
- Protection to logic supply under-voltage / accidental shutdown
- Feedback signals for 3 motor currents
- Feedback for DC bus voltage
- Single-ended encoder inputs
- Hall sensors inputs
- RS-232 serial communication port
- Standard MC-BUS interface with the control unit

This page is empty

## 2. PM50 v2.0 Operation

This chapter describes the operation of the PM50 v2.0 power module. Information is provided on the PM50's various interfaces.

### Contents

- 2.1 Board Layout
- 2.2 Power Supply
  - 2.2.1 J5 – Supply Connector
- 2.3 Power Stage Module
  - 2.3.1 3-phase Inverter Command
  - 2.3.2 Protections. Error Signal
  - 2.3.3 Current Measurement Interface
  - 2.3.4 Motor Supply / DC-bus Voltage Measurement
  - 2.3.5 J3 – Motor and Hall Sensors Connector
  - 2.3.6 J6 – Encoder Connector
- 2.4 Communication
  - 2.4.1 J4 – RS-232 Connector
- 2.5 Control Unit Interface (MC-Bus)
  - 2.5.1 J1, J2 – MC-Bus Connectors
- 2.6 JP1 – Jumper

## 2.1. Board Layout

Figure 2.1 presents the PM50 v2.0 board layout. Pin 1 for all the connectors and the jumper is marked on the layout with a square pad.

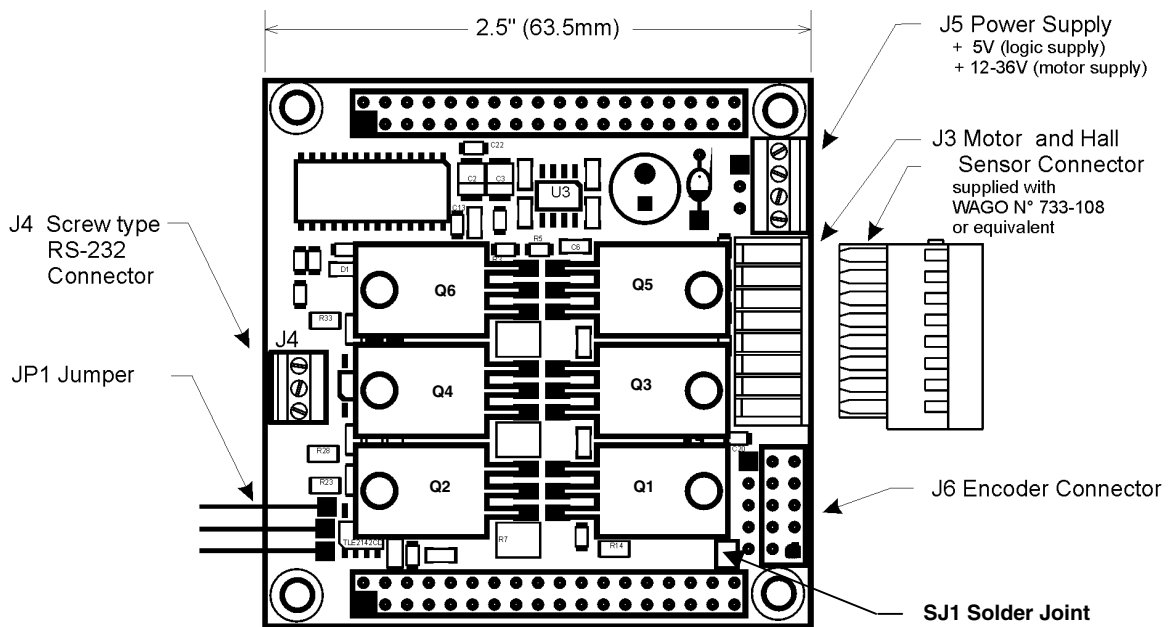

Figure 2.1. PM50 v2.0 Board Layout

## 2.2. Power Supply

### 2.2.1. J5 – Supply Connector

The PM50 v2.0 requires two power supplies:

- 5V<sub>DC</sub> for the internal logic
- 12 – 36 V<sub>DC</sub> for the motor

The motor power supply is applied on the inverter DC-bus and must be adapted to the motor and application requirements. It should be able to absorb the energy generated during motor braking. At power-on, the logic supply has to be applied first. If this condition is not respected, the protection for accidental logic supply shutdown will be triggered.

### **CAUTION !**

**Be careful to correctly connect the power supplies polarities! Reverse polarities may damage the PM50 module!**

By default, the PM50 v2.0 is equipped with a 4-pin 0.1" pitch screw-terminal connector for the supply. Its pin assignment is presented in Table 2.1.

**Table 2.1.** J5 – Supply Connector (default): 4-pin 0.1" pitch screw-terminal connector

| Pin | Name | Type | Function                     |
|-----|------|------|------------------------------|
| 1   | +5   | I    | 5V power supply plus (+)     |
| 2   | GND  | I    | 5V power supply minus (-)    |
| 3   | GND  | I    | Motor power supply minus (-) |
| 4   | +MOT | I    | Motor power supply plus (+)  |

On request the PM50 v2.0 can also be equipped with 2 other types of connectors for the supply:

- a 3-pin 0.1" pitch Wago 90° connector (J55). Its pin assignment is presented in Table 2.2
- a 4-pin 0.1" pitch Molex 90° connector (J555) with the same pin assignment as J5

**Table 2.2.** J55 – Supply Connector (alternate option): 3-pin 0.1" pitch Wago 90° connector

| Pin | Name | Type | Function                    |
|-----|------|------|-----------------------------|
| 1   | +5   | I    | 5V power supply plus (+)    |
| 2   | GND  | I    | Common supply minus (-)     |
| 3   | +MOT | I    | Motor power supply plus (+) |

### 2.3. Power Stage Module

The PM50 v2.0 power stage module includes a 3-phase inverter, the protection circuits and the measurement circuits for the DC-bus voltage and the motor currents.

#### 2.3.1. 3-phase Inverter Command

The 3-phase inverter (see figure 2.2) uses MOSFET transistors with switching frequency up to 100kHz. The PM50 v2.0 MC-bus interface includes 6 PWM command inputs (TTL/CMOS compatible) named  $\overline{\text{PWM1}}$  to  $\overline{\text{PWM6}}$  through which the control unit can drive each transistor of the inverter.

All PWM commands are active low.  $\overline{\text{PWM1}}$ ,  $\overline{\text{PWM3}}$ ,  $\overline{\text{PWM5}}$  drive the upper transistors.  $\overline{\text{PWM2}}$ ,  $\overline{\text{PWM4}}$ ,  $\overline{\text{PWM6}}$  drive the lower transistors.  $\overline{\text{PWM1}}$  &  $\overline{\text{PWM2}}$  drive phase A,  $\overline{\text{PWM3}}$  &  $\overline{\text{PWM4}}$  drive phase B,  $\overline{\text{PWM5}}$  &  $\overline{\text{PWM6}}$  drive phase C. The control unit PWM commands should include a dead-time of minimum 0.5 $\mu$ s for transistor's commutation.

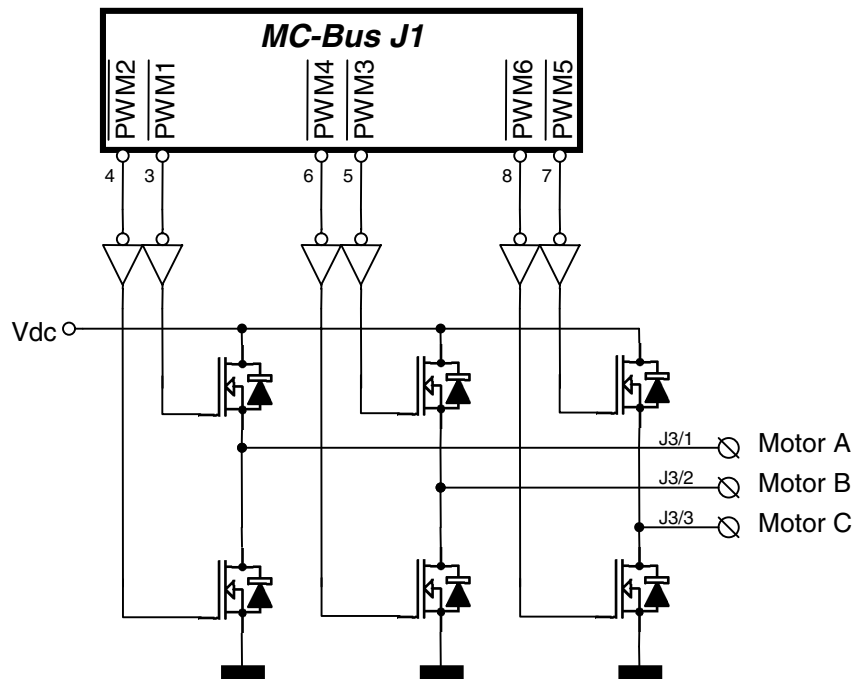

**Figure 2.2.** 3-phase Inverter Control using PWM Command Inputs

### 2.3.2. Protections. Error Signal

The PM50 v2.0 power stage includes protection circuits for: phase to phase short-circuit, over-current, over-voltage and accidental shutdown of logic supply (logic supply under-voltage). If any of these protections is triggered, the PM50 v2.0 sets low the MC-bus error signal  $\overline{\text{PDPINT}}$  (open-collector signal) to sign this event to the control unit and the inverter transistors are turned off as long as the condition is maintained. If any low-leg motor current exceeds 7A for more than 10 ms, a  $\overline{\text{PDPINT}}$  fault signal will occur. Short-term over-voltages having energy of less than 3J ( $47\text{V} \times 5\text{A} \times 12\text{ms}$ ) will be clamped by an on-board 47V suppresser.

### 2.3.3. Current Measurement Interface

The PM50 v2.0 measures the motor currents using shunts placed in the lower-legs of the inverter (see Figure 2.3) using a current gain factor of 0.395V/A, which translates +/-6.33A currents into +/-2.5V voltages. These voltages are applied on the MC-bus analogue outputs IA, IB and IC with a 2.5V offset. Hence positive currents are measured between 2.5V to 5V and negative currents are measured between 0 and 2.5V. The midpoint 2.5V corresponds to a zero current.

**Remark:** A positive current is defined as flowing from the lower transistor/diode to ground e.g. when the motor sinks the current. A negative current is defined as flowing from ground to the lower transistor/diode e.g. when the motor sources the power supply.

**WARNING:** Be aware that the current measurement scheme, simple and cost-effective from the hardware point of view, requires some special care from the point of view of software implementation. Thus, for the three currents measurement scheme, the A/D conversion **MUST** be synchronized with the PWM command of the inverter transistors, to properly measure the currents on each phase of the motor.

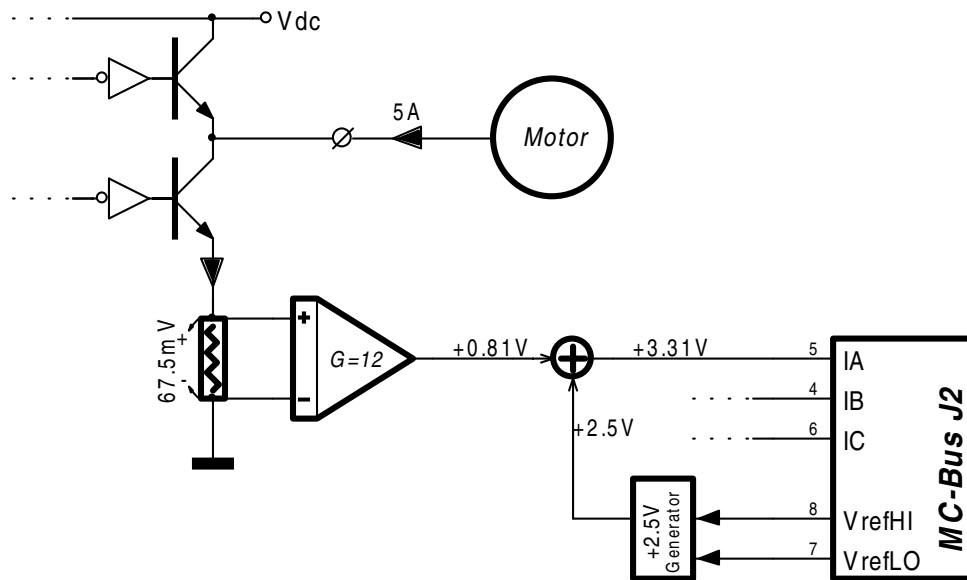

**Figure 2.3.** Current Measurement

**2.3.4. Motor Supply / DC-bus Voltage Measurement**

The PM-50 v 2.0 includes a motor supply / DC-bus voltage feedback applied on the MC-bus analogue input named VDC. The gain factor is 0.091. Hence, DC-bus voltages between 0 and 55V are translated into 0 to 5V at VDC output.

The measurement scheme provides filtering with a time constant of 8.6 ms, in order to remove spurious switching noise generated by the on-board power stage.

**2.3.5. J3 – Motor and Hall Sensors Connector**

By default, the PM50 v2.0 is equipped with an 8-pin 0.1” pitch Wago 90° connector for the motor. Its pin assignment is presented in Table 2.3. On request, the PM50 v2.0 can also be equipped with an 8-pin 0.1” pitch screw-terminal connector (J33) with the same pin assignment as J3.

**Table 2.3.** J3 – Motor Connector (default): 8-pin 0.1” pitch Wago 90° connector

| Pin | Name  | Type | Function                           |
|-----|-------|------|------------------------------------|
| 1   | U     | O    | Phase A for 3-phase motors         |
| 2   | V     | O    | Phase B for 3-phase motors         |
| 3   | W     | O    | Phase C for 3-phase motors         |
| 4   | +5V   | O    | +5V <sub>DC</sub> for Hall sensors |
| 5   | HALL1 | I    | Hall 1                             |
| 6   | HALL2 | I    | Hall 2                             |
| 7   | HALL3 | I    | Hall 3                             |
| 8   | GND   |      | Ground                             |

### 2.3.6. J6 – Encoder Connector

By default, the PM50 v2.0 is equipped with a 2x5 0.1” pitch header connector for the encoder. Its pin assignment is presented in Table 2.4. The encoder connector can be configured from **SJ1** solder joint to be compatible with API-Portescap A22 encoders or Hewlett Packard/Agilent HEDL65xx encoders. The **SJ1** solder joint must be:

- **ON** for HP HEDL65xx encoder type
- **OFF** for API-Portescap A22 encoder type (default)

**Table 2.4.** J6 – Encoder Connector (default): 2x5 0.1” pitch header connector

| Pin | Name                     | Type | Function  |
|-----|--------------------------|------|---|
| 1   | GND                      |      | Ground  |
| 2   | +5V                      | O    | Encoder supply  |
| 3   | DIR                      |      | Connected to ground if SJ1 = ON (see note)                        |
| 4   | $\overline{\text{STBY}}$ | I    | Connected to +5V  |
| 5   | -                        | n.c. | Not connected   |
| 6   | A                        | I    | Positive A for differential encoder or A for single-ended encoder |
| 7   | -                        | n.c. | Not connected   |
| 8   | B                        | I    | Positive B for differential encoder or B for single-ended encoder |
| 9   | -                        | n.c. | Not connected   |
| 10  | Z                        | I    | Positive Z for differential encoder or Z for single-ended encoder |

**Table 2.5.** J66 – Encoder Connector (alternate option): 5-pin Molex connector

| Pin | Name | Type | Function  |
|-----|------|------|---|
| 1   | GND  |      | Ground  |
| 2   | Z    | I    | Positive Z for differential encoder or Z for single-ended encoder |
| 3   | A    | I    | Positive A for differential encoder or A for single-ended encoder |
| 4   | +5V  | O    | Encoder sensor supply   |
| 5   | B    | I    | Positive B for differential encoder or B for single-ended encoder |

On request, the PM50 v2.0 can also be equipped with a vertical (J666) or 90° (J66) 5-pin Molex connector for the encoder, which is compatible with all Hewlett Packard/Agilent HEDSxxxx single-ended TTL-compatible encoders. Table 2.5 presents the pin assignment the for Molex connectors.

## 2.4. Communication

### 2.4.1. J4 – RS-232 Connector

The PM50 v2.0 power module offers an RS-232 serial channel. The control unit must provide on the MC-bus interface the Rx232 and Tx232 signals. The PM50 v2.0 applies them to the 3-wire RS-232 connector. The RS-232 transceiver should be on the control unit.

By default, the PM50 v2.0 is equipped with a 3-pin 0.1” pitch screw-terminal connector for RS-232 link. Its pin assignment is presented in Table 2.6. On request, the PM50 v2.0 can also be equipped with a 0.15” pitch Phoenix Contact Plug connector type MC1.5/3-G-3.81 with the same pin out as J4.

**Table 2.6.** J4 – RS-232 Connector (default): 3-pin 0.1” pitch screw-terminal connector

| Pin | Name | Type | Function          |
|-----|------|------|-------------------|
| 1   | TxD  | O    | Data Transmission |
| 2   | GND  |      | Ground            |
| 3   | RxD  | I    | Data Reception    |

A serial cable between the PM50 v2.0 power module and a PC must have the connections described in Table 2.7.

**Table 2.7.** RS-232 serial cable connections

| Signal Name   | Pin Assignments |            |                      |
|---------------|-----------------|------------|----------------------|
|               | PC side         |            | PM50 v2.0side        |
|               | DB25 Female     | DB9 Female | J4 or J44 connectors |
| Transmit Data | 2               | 3          | 1                    |
| Receive Data  | 3               | 2          | 3                    |
| Signal ground | 7               | 5          | 2                    |

## 2.5. Control Unit Interface (MC-Bus)

### 2.5.1. J1, J2 – MC-Bus Connectors

The PM50 v2.0 power module receives the PWM command signals and sends the feedback and status signals to the control unit through the two 2x18-pin 0.1” pitch MC-Bus connectors J1 and J2. The MC-Bus is a standard interface that permits to connect different Technosoft control and measurement modules with a range of power modules including PM50 v2.0. Tables 2.8 and 2.9 present the PM50 v2.0 pin assignment on the MC-Bus connectors. By default, the PM50v2.0 is

delivered with PC-104 connectors on the MC-Bus, to allow control unit connecting either over or under the PM50 v2.0.

**Table 2.8.** J1 – MC-bus connector

| Pin | Name                       | Type           | Description   |
|-----|----------------------------|----------------|---|
| 1   | -reserved-                 | n.c.           | Not connected on the PM50 v2.0  |
| 2   | -reserved-                 | n.c.           |   |
| 3   | $\overline{\text{PWM1}}$   | I <sup>1</sup> | CU <sup>2</sup> output. Active low command for the upper transistor, A-phase leg          |
| 4   | $\overline{\text{PWM2}}$   | I              | CU output. Active low command for the lower transistor, A-phase leg                       |
| 5   | $\overline{\text{PWM3}}$   | I              | CU output. Active low command for the upper transistor, B-phase leg                       |
| 6   | $\overline{\text{PWM4}}$   | I              | CU output. Active low command for the lower transistor, B-phase leg                       |
| 7   | $\overline{\text{PWM5}}$   | I              | CU output. Active low command for the upper transistor, C-phase leg                       |
| 8   | $\overline{\text{PWM6}}$   | I              | CU output. Active low command for the lower transistor, C-phase leg                       |
| 9   | -reserved-                 | n.c.           | Not connected on the PM50 v2.0  |
| 10  | -reserved-                 | n.c.           | Not connected on the PM50 v2.0  |
| 11  | -reserved-                 | n.c.           | Not connected on the PM50 v2.0  |
| 12  | -reserved-                 | n.c.           | Not connected on the PM50 v2.0  |
| 13  | -reserved-                 | n.c.           | Not connected on the PM50 v2.0  |
| 14  | -reserved-                 | n.c.           | Not connected on the PM50 v2.0  |
| 15  | -reserved-                 | n.c.           | Not connected on the PM50 v2.0  |
| 16  | -reserved-                 | n.c.           | Not connected on the PM50 v2.0  |
| 17  | ENC-A                      | O <sup>3</sup> | CU input. Encoder signal A from J6, J66 or J666   |
| 18  | ENC-B                      | O              | CU input. Encoder signal B from J6, J66 or J666   |
| 19  | ENC-Z                      | O              | CU input. Encoder signal Z (index/zero) from J6, J66 or J666                              |
| 20  | -reserved-                 | n.c.           | Not connected on the PM50 v2.0  |
| 21  | $\overline{\text{PDPINT}}$ | O              | CU input. Power stage error signal, driven by protection circuitry. Open-collector signal |
| 22  | -reserved-                 | n.c.           | Not connected on the PM50 v2.0  |
| 23  | -reserved-                 | n.c.           |   |
| 24  | -reserved-                 | n.c.           |   |
| 25  | +5V <sub>DC</sub>          | O              | +5V <sub>DC</sub> from J5 or J55 connectors   |
| 26  | DGND                       |                | Ground terminal. All digital signals are referenced to this signal                        |
| 27  | DGND                       |                |   |
| 28  | DGND                       |                |   |
| 29  | DGND                       |                |   |
| 30  | -reserved-                 | n.c.           | Not connected on the PM50 v2.0  |
| 31  | -reserved-                 | n.c.           |   |
| 32  | -reserved-                 | n.c.           |   |
| 33  | -reserved-                 | n.c.           |   |
| 34  | -reserved-                 | n.c.           |   |
| 35  | -reserved-                 | n.c.           |   |
| 36  | -reserved-                 | n.c.           |   |

<sup>1</sup> I – input in PM50 v2.0, output from control unit

<sup>2</sup> CU – control unit connected through the MC-bus with PM50 v2.0

<sup>3</sup> O – output from PM50 v2.0, input in CU

**Table 2.9.** J2 – MC-bus connector

| Pin | Name               | Type | Description   |
|-----|--------------------|------|---|
| 1   | -reserved-         | n.c. | Not connected on the PM50 v2.0  |
| 2   | -reserved-         | n.c. |   |
| 3   | VDC                | O    | CU analog input. Value of the motor supply / DC-bus voltage. Gain factor is 91mV/V  |
| 4   | IB                 | O    | CU analog input. Value of current in B-phase inverter lower leg, upper shifted with 2.5V. Gain factor is 0.395V/A   |
| 5   | IA                 | O    | CU analog input. Value of current in A-phase inverter lower leg, upper shifted with 2.5V. Gain factor is 0.395V/A   |
| 6   | IC                 | O    | CU analog input. Value of current in C-phase inverter lower leg, upper shifted with 2.5V. Gain factor is 0.395V/A   |
| 7   | V <sub>REFLO</sub> | O    | Analogue ground. Separated from DGND. The connection between these two signals must be done on the CU   |
| 8   | +5V <sub>A</sub>   | I    | Analogue reference. CU must provide the +5V <sub>A</sub> . Half of this value represents the upper shift for bipolar signals. Typical expected value is +5V, allowed range is +4.75...5.25V. Current drawn by PM50 v2.0 is under 0.5 mA |
| 9   | DGND               |      | Ground terminal. All digital signals are referenced to this signal  |
| 10  | DGND               |      |   |
| 11  | Hall 1             | O    | CU input. HALL1 signal from J3 or J33 connectors  |
| 12  | -reserved-         | n.c. | Not connected on the PM50 v2.0  |
| 13  | Hall 2             | O    | CU input. HALL2 signal from J3 or J33 connectors  |
| 14  | Hall 3             | O    | CU input. HALL3 signal from J3 or J33 connectors  |
| 15  | DGND               |      | Ground terminal. All digital signals are referenced to this signal  |
| 16  | -reserved-         | n.c. | Not connected on the PM50 v2.0  |
| 17  | Rx232              | O    | CU RS-232 input linked directly to J4 or J44 connectors pin 3   |
| 18  | Tx232              | I    | CU RS-232 output, linked directly to J4 or J44 connectors pin 1   |
| 19  | -reserved-         | n.c. | Not connected on the PM50 v2.0  |
| 20  | -reserved-         | n.c. |   |
| 21  | +5V <sub>DC</sub>  | O    | +5V <sub>DC</sub> from J5 or J55 connectors   |
| 22  | +5V <sub>DC</sub>  | O    |   |
| 23  | -reserved-         | n.c. | Not connected on the PM50 v2.0  |
| 24  | -reserved-         | n.c. | Not connected on the PM50 v2.0  |
| 25  | -reserved-         | n.c. | Not connected on the PM50 v2.0  |
| 26  | -reserved-         | n.c. | Not connected on the PM50 v2.0  |
| 27  | -reserved-         | n.c. | Not connected on the PM50 v2.0  |
| 28  | -reserved-         | n.c. | Not connected on the PM50 v2.0  |
| 29  | -reserved-         | n.c. | Not connected on the PM50 v2.0  |
| 30  | -reserved-         | n.c. | Not connected on the PM50 v2.0  |
| 31  | In                 | O    | CU input. Provides JP1 position: 1 logic -> JP1 =1-2, 0 logic -> JP1=2-3  |
| 32  | -reserved-         | n.c. | Not connected on the PM50 v2.0  |
| 33  | -reserved-         | n.c. | Not connected on the PM50 v2.0  |
| 34  | -reserved-         | n.c. | Not connected on the PM50 v2.0  |
| 35  | -reserved-         | n.c. | Not connected on the PM50 v2.0  |
| 36  | -reserved-         | n.c. | Not connected on the PM50 v2.0  |

## **2.6. JP1 - Jumper**

The PM50 v2.0 power module provides one jumper JP1 whose position determines the level of the digital input In connected to the MC-Bus:

- JP1 = 1-2, In signal is high (1 logic)
- JP2 = 2-3, In signal is low (0 logic)

## Appendices

### Appendix A. PM50 v2.0 Electrical Specifications

| Parameter                                      | Conditions  | Min.  | Typ.  | Max.  | Units   |
|--|---|-------|-------|-------|---------|
| <b>DC Input Power</b>                          |   |       |       |       |         |
| Logic supply                                   |   | 4.5   | 5     | 5.5   | V       |
| Motor supply                                   |   | 1     |       | 36    | V       |
| Logic input current                            | Required by PM50 v2.0 only. For total rating, add the control unit current                          |       |       | 0.15  | A       |
| Motor supply current                           |   |       |       | 2.1   | Arms    |
| Motor supply current                           |   |       |       | 6.33  | Apeak   |
| <b>Output Power</b>                            |   |       |       |       |         |
| Voltage  | set by external PWM control   | 0     |       | 36    | Vrms    |
| Nominal Motor Power                            | $V_{in}=36V, f_{pwm}=20kHz, T_A=40^{\circ}C$  |       |       | 75    | W       |
| Nominal Motor Current                          | $T_A=40^{\circ}C$   |       |       | 1.7   | Arms    |
| Overload Motor Current                         | $V_{in}=36V$ , nominal full load current, $f_{pwm}=20kHz$ , 0.1 sec. duration                       |       |       | 6.33  | Apeak   |
| PWM frequency                                  |   | 0.1   | 20    | 100   | kHz     |
| Inverter output dead band                      | Measured at inverter outputs using PWM commands with dead time of 0.5 $\mu s$ , $T_A = 25^{\circ}C$ |       | 0.2   |       | $\mu s$ |
| <b>Protections</b>                             |   |       |       |       |         |
| Output current trip level                      | $T_C = 25^{\circ}C$   |       |       | 7     | Apeak   |
| Over-voltage trip level                        |   | 44    | 47    | 50    | V       |
| Under-voltage trip level                       | Referring to internal +12V supply, derived from logic supply (+5V)                                  | 10    |       | 11    | V       |
| Short circuit shutdown time                    | Output terminals shorted  |       | 0.5   |       | ms      |
| <b>Inputs from MC-BUS</b>                      |   |       |       |       |         |
| PWM dead band command                          | Measured at MC-BUS pins, over operating ambient temperature   | 0.2   | 0.5   |       | $\mu s$ |
| High level input voltage                       | TTL compatible  | 2     |       |       | V       |
| Low level input voltage                        | TTL compatible  |       |       | 0.8   | V       |
| High level input current                       | Compatible with open-collector outputs  | 0     |       | 0     | mA      |
| Low level input current                        |   |       |       | 2     | mA      |
| <b>Analog Outputs to MC-BUS</b>                |   |       |       |       |         |
| Gain of 3 motor currents feedback              | Low-side leg inverter current   |       | 0.395 |       | V/A     |
| Offset of 3 motor currents feedback            |   | 2.375 | 2.5   | 2.625 | V       |
| Cut-off frequency of 3 motor currents feedback |   |       | 1.5   |       | MHz     |

## Appendices

---

|   |               |  |      |     |                     |
|---|---------------|--|------|-----|---------------------|
| DC bus voltage feedback gain                  |               |  | 90.9 |     | mV/V <sub>BUS</sub> |
| Cut-off frequency of DC bus voltage           |               |  | 730  |     | Hz                  |
| Setting time of the 3 motor currents feedback | 0.1% accuracy |  |      | 400 | ns                  |

### ***Digital Outputs to MC-BUS***

|   |                                 |  |   |  |   |
|---|---------------------------------|--|---|--|---|
| High level output voltage for Mon/User MC-BUS pin | Direct link to +5V logic supply |  | 5 |  | V |
| Low level output voltage for Mon/User MC-BUS pin  | Direct link to ground           |  | 0 |  | V |

### ***Hall Inputs from motor connector***

|                          |                         |   |  |     |    |
|--------------------------|-------------------------|---|--|-----|----|
| High level input current | Pull-up resistor to +5V | 0 |  | 0   | mA |
| Low level input current  |                         |   |  | 1.2 | mA |

### ***System Environment***

|                         |                             |   |  |    |    |
|-------------------------|-----------------------------|---|--|----|----|
| Ambient Operating Temp. | 90%RH max. (non-condensing) | 0 |  | 55 | °C |
|-------------------------|-----------------------------|---|--|----|----|

**Appendix B. MC-Bus Pin Correspondence with IMMC240 v3.0 and MCSK v1.0**

**J1 – MC-bus connector**

| Pin | PM50 v2.0 signal           | IMMC240 signal             | MCSK signal                |
|-----|----------------------------|----------------------------|----------------------------|
| 1   | n.c.                       | n.c.                       | n.c.                       |
| 2   | n.c.                       | n.c.                       | n.c.                       |
| 3   | $\overline{\text{PWM1}}$   | PWM1                       | $\overline{\text{PWM1}}$   |
| 4   | $\overline{\text{PWM2}}$   | PWM2                       | $\overline{\text{PWM2}}$   |
| 5   | PWM3                       | PWM3                       | PWM3                       |
| 6   | $\overline{\text{PWM4}}$   | PWM4                       | $\overline{\text{PWM4}}$   |
| 7   | PWM5                       | PWM5                       | PWM5                       |
| 8   | $\overline{\text{PWM6}}$   | PWM6                       | $\overline{\text{PWM6}}$   |
| 9   | n.c.                       | CMP7 / IOPB0               | IO#4/ BRAKE                |
| 10  | n.c.                       | CMP8 / IOPB1               | IO#5                       |
| 11  | n.c.                       | CMP9 / IOPB2               | IO#6                       |
| 12  | n.c.                       | T1CMP / IOPB3              | IO#7                       |
| 13  | n.c.                       | T2CMP / IOPB4              | IO#8                       |
| 14  | n.c.                       | T3CMP / IOPB5              | IO#9                       |
| 15  | n.c.                       | TMRDIR / IOPB6             | IO#10/DIR                  |
| 16  | n.c.                       | TMRCLK / IOPB7             | IO#11/PULSE                |
| 17  | ENC-A                      | QEP1 / IOPC4               | IO#16/ENCA                 |
| 18  | ENC-B                      | QEP2 / IOPC5               | IO#17/ENCB                 |
| 19  | ENC-Z                      | CAP3 / IOPC6               | IO#18/CAPI/HALL1           |
| 20  | n.c.                       | CAP4 / IOPC7               | IO#19/CAPH/DIR             |
| 21  | $\overline{\text{PDPINT}}$ | $\overline{\text{PDPINT}}$ | $\overline{\text{PDPINT}}$ |
| 22  | n.c.                       | XINT2 / IO                 | LSP                        |
| 23  | n.c.                       | SCIRXD / IO                | SCIRXD                     |
| 24  | n.c.                       | SCITXD / IO                | SCITXD                     |
| 25  | +5V <sub>DC</sub>          | +5V <sub>DC</sub>          | +5V <sub>DC</sub>          |
| 26  | DGND                       | DGND                       | DGND                       |
| 27  | DGND                       | DGND                       | DGND                       |
| 28  | DGND                       | DGND                       | DGND                       |
| 29  | DGND                       | DGND                       | DGND                       |
| 30  | n.c.                       | VrefLO                     | V <sub>REF</sub> LO        |
| 31  | n.c.                       | ADCIN5                     | TEMP1/TQLIM/ADCIN5         |
| 32  | n.c.                       | ADCIN13                    | n.c.                       |
| 33  | n.c.                       | ADCIN6                     | FEEDBACK/ADCIN6            |
| 34  | n.c.                       | ADCIN14                    | REFERENCE/ADCIN14          |
| 35  | n.c.                       | ADCIN7                     | ADCIN7                     |
| 36  | n.c.                       | ADCIN15                    | TEMP2/TQFFW/ADCIN15        |

**J2 – MC-bus connector**

| Pin | PM50 v2.0 signal   | IMMC240 signal     | MCSK signal        |
|-----|--------------------|--------------------|--------------------|
| 1   | n.c.               | ADCIN2             | CFG/ADCIN2         |
| 2   | n.c.               | ADCIN10            | ADCIN10            |
| 3   | VDC                | ADCIN3             | VDC/ADCIN3         |
| 4   | IV                 | ADCIN11            | IB/ADCIN11         |
| 5   | IU                 | ADCIN4             | IA/ADCIN4          |
| 6   | IW                 | ADCIN12            | IC/ADCIN12         |
| 7   | V <sub>REFLO</sub> | V <sub>REFLO</sub> | V <sub>REFLO</sub> |
| 8   | V <sub>REFHI</sub> | V <sub>REFHI</sub> | V <sub>REFHI</sub> |
| 9   | DGND               | DGND               | DGND               |
| 10  | DGND               | DGND               | DGND               |
| 11  | Hall 1             | IOPA0              | IO#0/HALL1         |
| 12  | n.c.               | IOPA3              | IO#3/TXEN485       |
| 13  | Hall 2             | IOPA1              | IO#1/HALL2         |
| 14  | Hall 3             | IOPA2              | IO#2/HALL3         |
| 15  | DGND               | DGND               | DGND               |
| 16  | n.c.               | DGND               | DGND               |
| 17  | Rx232              | RX                 | RxD                |
| 18  | Tx232              | TX                 | TxD                |
| 19  | n.c.               | n.c.               | n.c.               |
| 20  | n.c.               | n.c.               | n.c.               |
| 21  | +5V <sub>DC</sub>  | +5V <sub>DC</sub>  | +5V <sub>DC</sub>  |
| 22  | +5V <sub>DC</sub>  | +5V <sub>DC</sub>  | +5V <sub>DC</sub>  |
| 23  | n.c.               | PORESET            | PORESET            |
| 24  | n.c.               | - reserved -       | V <sub>EE</sub>    |
| 25  | n.c.               | - reserved -       | n.c.               |
| 26  | n.c.               | - reserved -       | n.c.               |
| 27  | n.c.               | SPISIMO / IO       | SPISIMO            |
| 28  | n.c.               | SPISOMI / IO       | SPISOMI            |
| 29  | n.c.               | SPICLK / IO        | SPICLK             |
| 30  | n.c.               | SPISTE / IO        | SPISTE             |
| 31  | In                 | ADCSOC / IOPC0     | AUTORUN            |
| 32  | n.c.               | CLKOUT / IOPC1     | CLKOUT/IO#13       |
| 33  | n.c.               | XF / IOPC2         | MCRDY              |
| 34  | n.c.               | BIO / IOPC3        | INT2HOST           |
| 35  | n.c.               | XINT3 / IO         | LSN                |
| 36  | n.c.               | NMI                | ENABLE             |

**Appendix C. MC-Bus Pin Correspondence with MSK243 v1.1**

**J1 – MC-bus connector**

| Pin | PM50 v2.0 signal  | MSK243 signal     |
|-----|-------------------|-------------------|
| 1   | n.c.              | n.c.              |
| 2   | n.c.              | n.c.              |
| 3   | PWM1              | PWM1              |
| 4   | PWM2              | PWM2              |
| 5   | PWM3              | PWM3              |
| 6   | PWM4              | PWM4              |
| 7   | PWM5              | PWM5              |
| 8   | PWM6              | PWM6              |
| 9   | n.c.              | IOPD2             |
| 10  | n.c.              | IOPD3             |
| 11  | n.c.              | IOPD4             |
| 12  | n.c.              | T1CMP / IOPB4     |
| 13  | n.c.              | T2CMP / IOPB5     |
| 14  | n.c.              | IOPD5             |
| 15  | n.c.              | TMRDIR / IOPB6    |
| 16  | n.c.              | TMRCLK / IOPB7    |
| 17  | ENC-A             | QEP1 / IOPA3      |
| 18  | ENC-B             | QEP2 / IOPA4      |
| 19  | ENC-Z             | CAP3 / IOPA5      |
| 20  | n.c.              | IOPD6             |
| 21  | PDPINT            | PDPINT            |
| 22  | n.c.              | XINT2 / IOPD1     |
| 23  | n.c.              | SCIRXD / IOPA1    |
| 24  | n.c.              | SCITXD / IOPA0    |
| 25  | +5V <sub>DC</sub> | +5V <sub>DC</sub> |
| 26  | DGND              | DGND              |
| 27  | DGND              | DGND              |
| 28  | DGND              | DGND              |
| 29  | DGND              | DGND              |
| 30  | n.c.              | VrefLO            |
| 31  | n.c.              | - n.c. - (ADCIN4) |
| 32  | n.c.              | n.c.              |
| 33  | n.c.              | ADCIN0            |
| 34  | n.c.              | ADCIN1            |
| 35  | n.c.              | ADCIN2            |
| 36  | n.c.              | ADCIN3            |

**J2 – MC-bus connector**

| Pin | PM50 v2.0 signal    | MSK243 signal     |
|-----|---------------------|-------------------|
| 1   | n.c.                | n.c.              |
| 2   | n.c.                | n.c.              |
| 3   | VDC                 | ADCIN4            |
| 4   | IV                  | ADCIN5            |
| 5   | IU                  | ADCIN6            |
| 6   | IW                  | ADCIN7            |
| 7   | V <sub>REF</sub> LO | VrefLO            |
| 8   | V <sub>REF</sub> HI | VrefHI            |
| 9   | DGND                | DGND              |
| 10  | DGND                | DGND              |
| 11  | Hall 1              | n.c. (see remark) |
| 12  | n.c.                | n.c.              |
| 13  | Hall 2              | n.c. (see remark) |
| 14  | Hall 3              | n.c. (see remark) |
| 15  | DGND                | DGND              |
| 16  | n.c.                | DGND              |
| 17  | Rx232               | RxD               |
| 18  | Tx232               | TxD               |
| 19  | n.c.                | CAN_HI            |
| 20  | n.c.                | CAN_VCC           |
| 21  | +5V <sub>DC</sub>   | +5V <sub>DC</sub> |
| 22  | +5V <sub>DC</sub>   | +5V <sub>DC</sub> |
| 23  | n.c.                | PORESET           |
| 24  | n.c.                | n.c.              |
| 25  | n.c.                | CAN_LO            |
| 26  | n.c.                | CAN_GND           |
| 27  | n.c.                | SPISIMO / IOPC2   |
| 28  | n.c.                | SPISOMI / IOPC3   |
| 29  | n.c.                | SPICLK / IOPC4    |
| 30  | n.c.                | SPISTE / IOPC5    |
| 31  | Mon/User            | IOPD7             |
| 32  | n.c.                | CLKOUT / IOPD0    |
| 33  | n.c.                | XF / IOPC0        |
| 34  | n.c.                | BIO / IOPC1       |
| 35  | n.c.                | XINT1 / IOPA2     |
| 36  | n.c.                | NMI               |

**Remark:** When MSK243v1.1 is delivered together with a PM50 v2.0, the MSK243 board includes an adapter. The adapter links the following MC-Bus signals: a) J2/pin 11 with J1/pin 11, b) J2/pin

13 with J1/pin14, c) J2/pin 14 with J1/pin 20. These links connect the Hall signals from PM50 v2.0 MC-Bus with three I/O pins of the MSK243.